

Joint Crediting Mechanism Rules and Guidelines Between the Cabinet of Ministers of the Kyrgyz Republic and Japan¹

CONTENTS

Joint Crediting Mechanism Rules of Procedures for the Joint Committee	2
Rules of Implementation for the Joint Crediting Mechanism (JCM)	5
Joint Crediting Mechanism Project Cycle Procedure.....	9
Joint Crediting Mechanism Guidelines for Developing Proposed Methodology	23
Joint Crediting Mechanism Guidelines for Developing Project Design Document and Monitoring Report.....	33
Joint Crediting Mechanism Guidelines for Developing Sustainable Development Implementation Plan and Report	47
Joint Crediting Mechanism Guidelines for Designation as a Third-Party Entity	55
Joint Crediting Mechanism Guidelines for Validation and Verification.....	60
Common Specifications of the JCM Registry.....	71

¹ Hereinafter referred to individually as “the government (of Partner Country/ Japan)” and collectively as “both governments”.

**Joint Crediting Mechanism
Rules of Procedures for the Joint Committee**

CONTENTS

1.	Objectives.....	3
2.	Scope.....	3
3.	Definitions.....	3
4.	Members.....	3
5.	Meetings.....	3
5.1.	Schedule.....	3
5.2.	Decision in the meeting	3
5.3.	Attendance.....	3
6.	Decision by electronic means and conference call.....	3
7.	Languages	3
8.	Secretariat.....	4
9.	External assistance	4
10.	Confidentiality.....	4
11.	Record of the meeting	4
12.	Conflict of interest.....	4

1. Objectives

1. The Rules of Procedures for the Joint Committee (hereinafter referred to as “Rules of Procedures”) delineates the membership, decision-making procedures, and activities of the Joint Committee of the Joint Crediting Mechanism (hereinafter referred to as “JCM”).

2. Scope

2. The Rules of Procedures apply to all activities of the Joint Committee, including, but not limited to those referred to in section C of the Rules of Implementation of the Joint Crediting Mechanism.

3. Definitions

3. Terms in the Rules of Procedures are defined in the JCM Glossary of Terms.

4. Members

4. The Joint Committee consists of representatives from the Government of Japan and the Government of (*Partner Country*).
5. Each government designates members of the Joint Committee from the respective government and notifies the other government of this designation in writing. Members of the Joint Committee designated by each government may not exceed 10. Members may be increased, decreased, or changed as long as they stay within the allowed number at any time with prior written notification of both governments.
6. Each member of the Joint Committee should have no personal or direct financial interest in any matter under consideration by the Joint Committee.
7. The Joint Committee has two Co-Chairs to be appointed by each government upon notification of each other with one of the Co-Chairs appointed by the Government of (*Partner Country*) and the other appointed by the Government of Japan, respectively. In case a Co-Chair resigns, the government which appointed the leaving Co-Chair, appoints his or her replacement.
8. Each Co-Chair may designate an alternate from members of the Joint Committee from each government to perform the function of the Co-Chair. Such designation is distributed electronically or otherwise, in written form.

5. Meetings**5.1. Schedule**

9. The Co-Chairs give notice of the date of each meeting no less than two weeks prior to the date of the meeting.
10. The Co-Chairs provide the agenda of each meeting no less than two weeks prior to the date of the meeting, and final draft of documents for the meeting no less than five working days prior to the date of the meeting.

5.2. Decision in the meeting

11. Decision by the Joint Committee is adopted by consensus.
12. The Co-Chairs ascertain whether consensus has been reached. The Co-Chairs declare that a consensus does not exist if there is a stated objection to the proposed decision by a member of the Joint Committee.

5.3. Attendance

13. An alternate of each member of the Joint Committee from the respective government may attend the meetings of the Joint Committee to perform the function of the member of the Joint Committee. Such substitution is informed by electronic means or otherwise in written form prior to the concerned meeting.
14. Meetings of the Joint Committee may be open to observers approved by both governments, except where otherwise decided by the Joint Committee. Observers may make presentations upon request by the Co-Chairs during the meeting.

6. Decision by electronic means and conference call

15. The Joint Committee may adopt decisions by electronic means provided that all the following procedures are made:
 - (a) The proposed decisions are distributed by the secretariat to all members of the Joint Committee by electronic means.
 - (b) The proposed decisions are deemed as adopted when,
 - (i) no member of the Joint Committee has provided negative assertion by electronic means within 10 calendar days after distribution of the proposed decisions, or
 - (ii) all members of the Joint Committee have made affirmative assertion by electronic means.
16. If a negative assertion is made by one of the members of the Joint Committee, the Co-Chairs take into account the opinion of the member and take appropriate actions.
17. The Joint Committee may hold conference calls to assist making decisions by electronic means.

7. Languages

18. The decisions of the Joint Committee are published in English.
19. Working language of the Joint Committee is English. Members of the Joint Committee wishing to speak or distribute materials in other languages provide for interpretation or translation in English.

8. Secretariat

20. The secretariat serves the Joint Committee by performing the work for the implementation of the JCM.

9. External assistance

21. The Joint Committee may establish panels necessary to assist it in the performance of its functions. The rules and procedures of such panels are decided by the Joint Committee.

22. The Joint Committee may decide to appoint external experts to assist part of its work on a case-by-case basis.

10. Confidentiality

23. Members of the Joint Committee, the secretariat or any other bodies or persons that have been delegated the work to assist the Joint Committee respect the confidentiality of all confidential information acquired in his/her position and not make improper use of or disclose such confidential information to third parties.

11. Record of the meeting

24. The full text of all decisions of the Joint Committee is made publicly available immediately after the decisions are adopted.

12. Conflict of interest

25. Any bodies or persons other than governmental officials who participate in the Joint Committee meeting or conference calls declare before their participation to such occasions that they have no current professional, financial or other interest which could: i) significantly impair the individual's objectivity in carrying out his or her duties for the Joint Committee, or ii) create an unfair advantage for any person or organization. Circumstances that could lead a reasonable person to question an individual's objectivity, or whether an unfair advantage has been created, constitute a potential conflict of interest.

Rules of Implementation for the Joint Crediting Mechanism (JCM)

The Joint Committee of the JCM between the Government of Japan and the Government of (*Partner Country*), hereby establishes the rules of implementation for the JCM as follows:

A. Purpose of the JCM

26. The JCM has the following purposes:
- (a) To facilitate diffusion of leading decarbonizing technologies, products, systems, services, and infrastructure as well as implementation of mitigation actions, and contribute to sustainable development of (*Partner Country*);
 - (b) To appropriately evaluate contributions to greenhouse gases (hereinafter referred to as “GHG”) emission reductions or removals in a quantitative manner through mitigation actions implemented in (*Partner Country*) and contribute to the achievement of nationally determined contributions of Japan and (*Partner Country*) under the Paris Agreement;
 - (c) To contribute to the ultimate objective of the United Nations Framework Convention on Climate Change (UNFCCC) by facilitating global actions for GHG emission reductions or removals.

B. Scope

27. GHGs are those gases of carbon dioxide (CO₂), methane (CH₄), nitrous oxide (N₂O), hydrofluorocarbons (HFCs), perfluorocarbons (PFCs), sulphur hexafluoride (SF₆) and nitrogen trifluoride (NF₃).
28. Credits under the JCM (hereinafter referred to as “JCM credits”) are issued based on quantified amount of GHG emission reductions or removals achieved by project participants in the implementation of GHG emission reductions or removals project activities under the JCM (hereinafter referred to as “JCM projects”).
29. Each JCM project selects the crediting period which is either a fixed period of 10 years, or a renewable period of five (5) years which may be renewed twice at the maximum, unless otherwise specified.

C. Joint Committee

30. Both governments establish the Joint Committee which consists of the representatives from both governments.
31. The Joint Committee may develop or modify the Rules of Implementation and other rules and guidelines necessary for the implementation of the JCM, including, but not limited to:
 - (a) rules of procedures of the Joint Committee;
 - (b) guidelines for the development of methodologies;
 - (c) methodologies;
 - (d) guidelines for developing project design document and monitoring report;
 - (e) guidelines for the sustainable development implementation plan and report;
 - (f) guidelines for the designation as a third-party entity;
 - (g) guidelines for the validation;
 - (h) monitoring guidelines;
 - (i) guidelines for the verification of GHG emission reductions or removals;
 - (j) common specifications for registries;
 - (k) forms for project design document (hereinafter referred to as “PDD”), sustainable development implementation plan (hereinafter referred to as “SDIP”), request for registration of JCM projects, monitoring report, sustainable development implementation report (hereinafter referred to as “SDIR”), request for verification of GHG emission reductions or removals.
32. The Joint Committee designates the third-party entities to conduct validation and/or verification under the JCM as referred to in paragraph 43.
33. On the basis of a Project Idea Note (hereinafter referred to as “PIN”) submitted by project participants, the Joint Committee decides to object or not to object to the planned project described in the PIN.
34. On the basis of a request for registration of JCM projects submitted by project participants, the Joint Committee registers JCM projects, which were validated by the third-party entities, and adopts the JCM credit allocation for the JCM projects.
35. On the basis of a request for notification to each government for issuance of JCM credits submitted by project participants, the Joint Committee notifies each government to issue the JCM credits, which were verified by the third-party entities.
36. The Joint Committee develops, where necessary, reports on the status of the implementation of the JCM and discusses issues related to the operation and management of the JCM.
37. In conjunction with meetings of the Joint Committee, both governments conduct policy consultations about the relevant policy measures of the JCM.
38. The Joint Committee establishes its secretariat for the implementation of the JCM.

D. Each Government

39. Each government, based on the rules and guidelines as developed by the Joint Committee and/or in accordance with relevant domestic laws and regulations in respective countries for the implementation of the JCM:

- (a) Establishes and maintains a registry in line with the common specifications for registries, as developed by the Joint Committee;
 - (b) On the basis of notification for issuance of JCM credits by the Joint Committee (including for allocation of JCM credits among participants), issues the notified amount of JCM credits to its registry.
40. Each government promptly informs the Joint Committee of the issuance of JCM credits.
41. Each government takes necessary measures to ensure transparency in the implementation of the JCM.
42. Neither government uses any mitigation projects registered under the JCM for the purpose of any other GHG mitigation crediting mechanisms to avoid double counting.

E. Third-party Entities

43. A third-party entity that is designated by the Joint Committee:
- (a) On the basis of requests from project participants, validates the project as described in a PDD prepared by the project participants, in line with the guidelines for the validation as developed by the Joint Committee, and informs the project participants of the validation result;
 - (b) On the basis of requests from project participants, verifies GHG emission reductions or removals achieved by the JCM project as described in the monitoring report prepared by the project participants, in line with the guidelines for the verification of GHG emission reductions or removals as developed by the Joint Committee, records the verification result in a verification report and sends the report to the project participants.

F. Project Participants

44. Project participants:
- (a) Prepare a PIN and submit it to the Joint Committee for its decision;
 - (b) Prepare a draft methodology and submit it to the Joint Committee for its approval;
 - (c) Prepare a draft PDD and submit it to a third-party entity for validation and to notify the Joint Committee for public inputs;
 - (d) Prepare an SDIP and submit it to the Joint Committee for review;
 - (e) Submit the PDD that was validated by the third-party entity, the JCM credit allocation form and positively reviewed SDIP to the Joint Committee for its registration of the JCM project;
 - (f) Implement the JCM project and conduct monitoring in line with the PDD;
 - (g) Prepare a project implementation report and submit it to the Joint Committee annually until the end of the operational lifetime of the JCM project or the end of the crediting period, whichever comes first;
 - (h) Prepare a monitoring report and send the report to a third-party entity for verification;
 - (i) Prepare an SDIR for each monitoring period and submit it to the Joint Committee for evaluation;
 - (j) Submit a verification report prepared by the third-party entity and evaluated SDIR to the Joint Committee, and request notification to each government for issuance of JCM credits.

G. Submission of Project Idea Note

45. The project participants prepare a PIN and submit it to the Joint Committee. Those planned projects described in the PINs to which the Joint Committee decides not to object may proceed to the request for registration of the project.

H. Development of Methodologies

46. Each government or project participant prepares a draft methodology and submits it to the Joint Committee. The submitted draft methodology, after its completeness being checked, goes through public inputs process.
47. The Joint Committee determines either to approve or reject the draft methodology, taking account of, among other things, inputs received and notifies the result to each government or project participant, as applicable. The Joint Committee makes publicly available the relevant information on the approved methodologies through a website.

I. Designation of Third-party Entities

48. Upon receiving an application for designation as a third-party entity submitted by a candidate, the Joint Committee designates a third-party entity in line with the guidelines for the designation as a third-party entity, and makes publicly available the relevant information on the designated third-party entity through a website.
49. The Joint Committee may suspend or withdraw the designation of a third-party entity if it has found fraud, malfeasance or incompetence of the entity.

J. Validation

50. Validation is the process of independent evaluation of a proposed JCM project by a third-party entity against the validation guidelines as developed by the Joint Committee on the basis of the PDD.
51. Project participants develop a PDD by filling in the form and request a third-party entity to validate the proposed JCM project.

52. The third-party entity, in line with the guidelines for the validation as developed by the Joint Committee, validates the proposed JCM project as described in the PDD and notifies the result of the validation to the project participants.

K. Review of Sustainable Development Implementation Plan

53. The project participants fill in the SDIP form in line with the guidelines for developing sustainable development implementation plan and report and submit it to the secretariat in line with the project cycle procedures.
54. By the end of the reviewing period, the secretariat notifies the project participants if potential negative impacts of the JCM project on sustainable development are identified and an appropriate action plan is not described.

L. Registration

55. Registration is the formal acceptance by the Joint Committee of a validated project as a JCM project.
56. Project participants of a JCM project consult among themselves and with both governments the JCM credit allocation among the project participants of Japan, the project participants of (*Partner Country*), the Government of Japan and the Government of (*Partner Country*) respectively, taking into consideration their respective contribution to GHG emission reductions or removals by the JCM project.
57. Project participants submit the PDD, which was validated by the third-party entity, the JCM credit allocation form and positively reviewed SDIP, to the Joint Committee and request for their registration.
58. Upon receiving a request for registration from project participants, the Joint Committee decides the JCM credit allocation, registers as the JCM project, notifies each government of the registration and makes publicly available the relevant information on the JCM project through a website.

M. Monitoring

59. Project participants implement a JCM project and monitor GHG emission reductions or removals by the JCM project based on the PDD.

N. Verification

60. Verification is the periodic independent review and ex post determination of monitored GHG emissions reductions or removals for a specific monitoring period of a registered JCM project conducted by a third-party entity.
61. Project participants prepare a monitoring report and request a third-party entity for verification.
62. The third-party entity, in line with the guidelines for the verification of GHG emission reductions or removals as developed by the Joint Committee, verifies the amount of GHG emission reductions or removals on the basis of the monitoring report submitted by the project participants, prepares a verification report and sends the report to the project participants which requested verification.

O. Evaluation of Sustainable Development Implementation Report

63. The project participants fill in the SDIR form in line with the guidelines for developing sustainable development implementation plan and report and positively reviewed SDIP, and submit it to the secretariat in line with the project cycle procedures.
64. By the end of the evaluation period, the secretariat notifies the project participants if negative impacts of the JCM project on sustainable development are identified without appropriate description on the corrective action.

P. Issuance of JCM Credits

65. Each government establishes a registry to record and use JCM credits, measured in metric tonnes of carbon dioxide equivalent (tCO₂eq) in line with the methodologies and metrics assessed by the Intergovernmental Panel on Climate Change.
66. Project participants request the Joint Committee to notify each government to issue JCM credits to its respective account in the registry on the basis of the verification report and evaluated SDIR, in line with the JCM credit allocation decided in paragraph 58.
67. Upon receiving the request for issuance of JCM credits from project participants, the Joint Committee notifies each government of the issuance of JCM credits.
68. The Joint Committee makes publicly available the relevant information on the issuance of JCM credits through a website.

Q. Use of JCM Credits

69. JCM credits issued from GHG emission reductions or removals that occurred on or after 1st January 2021 may be used towards the achievement of Japan's nationally determined contribution and the rest of the said JCM credits may contribute to the achievement of (*Partner Country*)'s nationally determined contribution, while ensuring that double counting is avoided on the basis of corresponding adjustments.
70. JCM credits are issued in the JCM registry of Japan and the JCM registry of (*Partner Country*) respectively with the avoidance of double counting. JCM credits issued by each government are tradable within its respective country.
71. JCM credits may not be traded between the JCM registry of Japan and the JCM registry of (*Partner Country*) unless each

government establishes necessary arrangements for the trade.

72. Each government authorizes the JCM credits issued in the JCM registry of Japan for the use toward the achievement of Japan's nationally determined contribution as internationally transferred mitigation outcomes, consistent with the guidance on cooperative approaches, referred to in Article 6, paragraph 2 of the Paris Agreement (hereinafter referred to as "the guidance").
73. Each government may authorize part of JCM credits for use for other international mitigation purposes, as appropriate, consistent with the guidance.
74. The Government of (*Partner Country*) applies corresponding adjustments to the JCM credits issued in the JCM registry of Japan as well as the JCM credits issued in the JCM registry of (*Partner Country*) and authorized for the use toward other international mitigation purposes, consistent with the guidance.
75. Each government checks the status of the issuance and use of JCM credits and makes sure that double counting is avoided as described in paragraphs 42 and 69.

R. Others

76. The JCM covers the period for verified emission reductions or removals from the mitigation projects under the JCM to be made until either government decides and notifies to the other government for the termination of the JCM.

Joint Crediting Mechanism Project Cycle Procedure

CONTENTS

1.	GENERAL PROCEDURES.....	10
1.1.	Objectives	10
1.2.	Scope and applicability	10
1.3.	Terms and definitions.....	10
1.4.	No objection to a planned project.....	10
1.5.	Approval of methodologies	111
1.6.	Implementation of project.....	12
1.7.	Pre-registration activities	12
1.8.	Registration of project.....	14
1.9.	Pre-issuance activities.....	15
1.10.	Issuance of credits.....	16
1.11.	Renewal of crediting period.....	17
2.	SPECIFIC PROCEDURES	18
2.1.	No objection to a planned project	18
2.2.	Approval of methodologies	18
2.3.	Pre-registration activities	19
2.4.	Registration of project.....	19
2.5.	Post-registration activities.....	19
2.6.	Issuance of credits.....	21
2.7.	Withdrawal.....	22

1. GENERAL PROCEDURES

1.1. Objectives

77. The objectives of the “Joint Crediting Mechanism Project Cycle Procedure” (hereinafter referred to as “this Procedure”) are to:
- (a) Improve the consistency and clarity in processing of the submissions of documents relating to the decision on no-objection for a planned project, the approval of a methodology, the registration of a proposed Joint Crediting Mechanism (hereinafter referred to as “JCM”) project and issuance of credits by the Joint Committee, its secretariat (hereinafter referred to as the “secretariat”), the Government of Japan and the Government of (*Partner Country*) (hereinafter referred to as “both governments”);
 - (b) Enhance the overall efficiency and integrity of the JCM.

1.2. Scope and applicability

78. This Procedure describes the administrative steps to follow for project participants, third-party entities (hereinafter referred to as the “TPEs”), other stakeholders, the Joint Committee, the secretariat and both governments for approval of a methodology, registration of a JCM project, issuance of credits and related actions.

1.3. Terms and definitions

79. This Procedure describes standards which are requirements to be met except those paragraphs which include terms “should” and “may” as defined in paragraph 80 below.
80. The following terms apply in this Procedure:
- (a) “Should” is used to indicate that among several possibilities, one course of action is recommended as particularly suitable;
 - (b) “May” is used to indicate what is permitted.
81. Terms in this Procedure are defined in the “Joint Crediting Mechanism Glossary of Terms” available on the JCM website.

1.4. No objection to a planned project

1.4.1. Submission of project idea note

82. The project participants of a planned project who seek to request registration under the JCM prepare a project idea note (hereinafter referred to as “PIN”) and submit it, using the latest version of the “JCM Project Idea Note Form”, to the Joint Committee through the secretariat, before implementing the project.
83. In case the project participants of the planned project expect to receive financial support for the project from the Government of Japan, the PIN should be submitted from a relevant ministry in the Government of Japan to the Joint Committee through the secretariat.
84. The project participants may submit the PIN using the previous version of the “JCM Project Idea Note Form” within the grace period of six (6) months from the date of publication of a new version. The Joint Committee does not accept the PIN using the previous version after the grace period of six (6) months.

1.4.2. Processing submission of project idea note

85. The secretariat issues a unique reference number to the PIN submitted to the Joint Committee through the secretariat.
86. The secretariat notifies the receipt of the submission of the PIN and a unique reference number to the project participants who have submitted the PIN.
87. Upon receiving the PIN, the secretariat conducts a completeness check within five (5) calendar days to determine whether the submission is complete.
88. Upon completion of the completeness check, the secretariat notifies the project participants of the result of the completeness check.

1.4.3. Finalizing processing of project idea note

89. Upon positive result of the completeness check, the Joint Committee decides whether it has objection or no objection to the planned project described in the PIN within fifteen (15) calendar days.
90. The Joint Committee makes the result publicly available, including the reference number of the PIN, the name of the planned project, the date of submission and the reason for objection when the Joint Committee objects to the planned project described in the PIN through the JCM website, and the secretariat notifies the project participants or the relevant ministry in the Government of Japan described in paragraph 83 of the result.
91. Upon decision by the Joint Committee on no objection to the planned project, the project participants may proceed to the processes described in section 1.7.
92. If the project participants wish to resubmit the PIN due to substantive changes after receiving a no objection, they may revise the PIN and submit the revised PIN to the Joint Committee for no objection through the secretariat or the relevant ministry of the Government of Japan, notifying the reference number which has already been issued to the planned project.
93. The project participants may resubmit a PIN that has been assessed as incomplete by the secretariat or has been given an objection by the Joint Committee. Such submission addresses the reasons for incompleteness stated by the secretariat and an

objection stated by the Joint Committee.

1.5. Approval of methodologies

1.5.1. Submission of a proposed methodology

94. The Government of Japan, the Government of (*Partner Country*) or project participants (hereinafter referred to as “methodology proponents”) may prepare a proposed methodology and submit it, using the latest version of forms described in paragraph 95 below, to the Joint Committee through the secretariat for its approval by electronic means.
95. The proposed methodology consists of the completed “JCM Proposed Methodology Form” and “JCM Proposed Methodology Spreadsheet Form”, containing the Input Sheet and Calculation Process Sheet, which are developed in line with the “Joint Crediting Mechanism Guidelines for Developing Proposed Methodology” (hereinafter referred to as “Methodology Guidelines”). The submission may be accompanied by additional documents which help explain the methodology. The Joint Committee may request the methodology proponents to submit additional documents including a draft project design document (hereinafter referred to as “PDD”) to which the proposed methodology is applied.
96. The methodology proponents may submit the proposed methodology to the Joint Committee through the secretariat for its approval using the previous version of the “JCM Proposed Methodology Form” and “JCM Proposed Methodology Spreadsheet Form” within the grace period of six (6) months from the date of publication of a new version. The Joint Committee does not accept the proposed methodology using the previous version after the grace period of six (6) months.
97. The secretariat notifies the receipt of the submission to the methodology proponents by electronic means.
98. Methodologies may also be developed under the initiative of the Joint Committee.

1.5.2. Completeness check

99. The secretariat checks whether the proposed methodology is complete and communicates the result to the methodology proponents within seven (7) calendar days after the receipt of the submission.
100. If the submission is deemed incomplete, the secretariat notifies the methodology proponents of the reason.
101. This process is not required for proposed methodologies developed under the initiative of the Joint Committee.

1.5.3. Public inputs

102. After the secretariat deems that the submitted proposed methodology satisfies the completeness check, the secretariat promptly makes the methodology publicly available for public inputs through the JCM website.
103. The duration of call for public inputs is fifteen (15) calendar days.
104. The secretariat makes all received inputs publicly available through the JCM website.
105. For methodologies developed under the initiative of the Joint Committee, they are also subjected to this process.

1.5.4. Review of a proposed methodology

106. After the public inputs, the secretariat reviews the proposed methodology based on, but not limited to, the materials submitted by the methodology proponents and the received inputs in line with Methodology Guidelines.
107. The secretariat may interact with the methodology proponents on specific issues regarding the proposed methodology.
108. The secretariat may delegate part of the work of review to external experts and/or a panel independent from methodology proponents, as appropriate.
109. This process is not required for proposed methodologies developed under the initiative of the Joint Committee.
110. Upon the completion of the review, the secretariat notifies the methodology proponents and submits the outcome to the Joint Committee.

1.5.5. Consideration of a proposed methodology

111. The Joint Committee receives the outcome of the secretariat’s review and considers the proposed methodology.
112. The Joint Committee may interact with the methodology proponents on specific issues regarding the proposed methodology.
113. The outcome of the consideration is as follows:
 - (a) Approval of the proposed methodology;
 - (b) Approval of the proposed methodology with revisions;
 - (c) Non-approval of the proposed methodology.
114. The Joint Committee should complete the consideration within sixty (60) calendar days from the closing of the secretariat review. If this is deemed not possible due to matters such as ongoing clarifications, then the secretariat notifies the methodology proponents of the status of discussion within sixty (60) calendar days from the closing of the secretariat review, and the Joint Committee should complete the consideration no later than ninety (90) calendar days from the closing of the secretariat review.
115. Upon completion of consideration, the secretariat notifies the outcome of consideration to the methodology proponents, with its reasons.
116. The secretariat makes publicly available the outcome of the consideration, as well as relevant information on the approved methodology, which consists of approved methodology document and Monitoring Spreadsheet, through the JCM website within five (5) calendar days from the date of decision by the Joint Committee. Monitoring Spreadsheet consists of Monitoring

Plan Sheet, Monitoring Structure Sheet and Monitoring Report Sheet².

117. The methodology proponents may resubmit any proposed methodology that has been assessed as incomplete by the secretariat or has not been approved by the Joint Committee. Such submission addresses the reasons for incompleteness stated by the secretariat or non-approval stated by the Joint Committee.
- 1.6. Implementation of project
118. Project participants operate a project in line with the JCM rules and guidelines.
119. After the registration of the project, the project participants operate the project and conduct monitoring of its activity in line with the registered PDD. The project participants may submit the request for registration after the start date of operation.
120. If the project participants identify risks that could significantly affect the project, the project participants report them to the secretariat without delay.
121. Credits are only issued to emission reductions or removals that are calculated by the project participants and verified by the TPE based on the results of monitoring in line with the registered PDD, after the start date of operation.
- 1.7. Pre-registration activities
- 1.7.1. Publication of project design document**
- 1.7.1.1. Assessment of reference emissions**
122. When preparing a draft PDD, the project participants of a proposed JCM project confirm the approval date of the latest version of the approved methodology which the project participants plan to apply. If five (5) years have passed since the approval date or, when applicable, the date of the last positive result decided by the Joint Committee on the validity of reference emissions, in line with this section or section 1.11.1, of the latest version of the approved methodology, the validity of reference emissions of the approved methodology to be applied is assessed as described in paragraphs 123 to 130 below unless otherwise revisions of reference emissions are required in the individual approved methodology applied to the JCM project.
123. The project participants evaluate the validity of the reference emissions of the applied methodology in line with the Methodology Guidelines.
124. If the reference emissions are not deemed to fulfill the requirements as a result of the evaluation described in paragraph 123, the project participants proceed to revision of an approved methodology(ies) applied in line with Section 2.2.1 below.
125. When the reference emissions are deemed to fulfill the requirements as a result of the evaluation described in paragraph 123, the project participants submit a request with relevant evidence of their evaluation to the Joint Committee through the secretariat for assessment on validity of reference emissions, using the latest version of “JCM Assessment of reference emissions request form”.
126. The secretariat conducts a completeness check of the submitted request within seven (7) calendar days to determine whether the submitted request is complete.
127. Upon completion of the completeness check, the secretariat notifies the project participants of the result of the completeness check.
128. Upon positive result of the completeness check, the Joint Committee assesses the submission in line with the Methodology Guidelines and decides the validity of reference emissions of the approved methodology.
129. Upon positive result on its validity of reference emissions of the approved methodology by the Joint Committee, the project participants may proceed to the processes described in section 1.7.1.2 below.
130. The project participants may request to revise the approved methodology in line with Section 2.2.1 below when the assessment by the Joint Committee does not complete in a positive result.
- 1.7.1.2. Submission of project design document**
131. When the approval date or the date of last positive result decided by the Joint Committee on the validity of reference emissions of the latest version of the approved methodology which the project participants plan to apply is within five (5) years or the assessment of the validity of reference emissions of the approved methodology as described in section 1.7.1.1 above is positively completed by the Joint Committee, the project participants of a proposed JCM project prepare a draft PDD, which consists of a completed “JCM Project Design Document Form”, using the latest version of that form, and monitoring plan, in line with the “Joint Crediting Mechanism Guidelines for Developing Project Design Document and Monitoring Report” (hereinafter referred to as “PDD and Monitoring Guidelines”), and submit them together with a modalities of communication statement (hereinafter referred to as “MoC”), using the latest version of the “JCM Modalities of Communication Statement Form” and supporting documentation, as appropriate, to the TPE contracted by the project participants to perform validation of the project and to the Joint Committee through the secretariat for public inputs.
132. The project participants may submit the draft PDD together with the MoC to the TPE contracted by the project participants to

² Monitoring Plan Sheet and Monitoring Report Sheet are prepared by the secretariat based on a Proposed Methodology Spreadsheet made by the methodology proponent after its approval. Monitoring Structure Sheet is added by the secretariat.

perform validation of the project and to the Joint Committee through the secretariat for public inputs, using the previous version of the “JCM Project Design Document Form” and “JCM Modalities of Communication Statement Form” within the grace period of six (6) months from the date of publication of a new version. The Joint Committee does not accept the draft PDD and the MoC using the previous version after the grace period of six (6) months.

133. When preparing a draft PDD, project participants select a crediting period from a fixed crediting period of ten (10) years or a renewable crediting period of five (5) years, unless otherwise specified.
134. The secretariat issues a unique reference number to the JCM project submitted to the Joint Committee through the secretariat for public inputs.
135. The secretariat notifies the receipt of the submission and the unique reference number to the project participant who has submitted the draft PDD and MoC.
136. Upon notifying the receipt of the submission, the secretariat makes the draft PDD publicly available through the JCM website for public inputs. The duration of call for public inputs on the draft PDD is thirty (30) calendar days subsequent to the publication of the draft PDD. The secretariat informs the project participants and the TPE of the location of the draft PDD on the JCM website and the opening and closing dates of the duration of call for public inputs.
137. In addition to the draft PDD, the secretariat, through the JCM website, also makes the following information publicly available:
 - (a) The name of the proposed JCM project;
 - (b) The location of the proposed JCM project including coordinates;
 - (c) The names of the all project participants listed in the draft PDD of the proposed JCM project;
 - (d) The name of the TPE which conducts validation (and verification) for the proposed JCM project;
 - (e) The estimated annual greenhouse gas (GHG) emission reductions or removals indicated in the draft PDD;
 - (f) The approved methodology(ies) being applied to the proposed JCM project;
 - (g) The proposed start date and length of the expected operation period;
 - (h) The crediting period of the proposed project.
138. Validation and verification can be conducted either simultaneously or separately. When the project participants apply for validation and verification simultaneously, all sections of the draft PDD and the draft monitoring report are completed prior to submission.

1.7.1.3. Submission and treatment of public inputs

139. All stakeholders may submit inputs, in English, on the proposed JCM project to the project participants and the TPE through electronic means specified on the JCM website. The submitters of the inputs provide the name and contact details of the individual or organization on whose behalf the inputs are submitted. The TPE checks the authenticity and relevance of this information in case of doubt.
140. The secretariat makes the inputs publicly available through the JCM website where the draft PDD is displayed, and removes those that the TPE has determined to be unauthentic in line with paragraph 139 above.

1.7.2. **Modalities of communication**

141. The project participants of a JCM project designate one focal point entity (hereinafter referred to as the “focal point”) from the project participants to communicate on their behalf with the Joint Committee and the secretariat in line with scopes of authority referred to in paragraph 144 below and include this information in an MoC.
142. After the submission of an MoC of a proposed JCM project, all official communication between the project participants and the Joint Committee, the secretariat, or each government for the specific project is conducted through the focal point.
143. The project participants submit an MoC to the Joint Committee through the secretariat and the TPE, at the time of submitting the draft PDD to the TPE for validation and the Joint Committee for public inputs. The contact details of the focal point and other project participants are included in the “JCM Modalities of Communication Statement Form”.
144. The project participants grant the focal point the authority to:
 - (a) Communicate in relation to requests for issuance of credits to respective accounts;
 - (b) Communicate in relation to requests for addition and/or voluntary withdrawal of project participants and changes to the focal point, as well as changes to company names, legal status, contact details and specimen signatures; and
 - (c) Communicate on all other project-related matters not covered by subparagraphs (a) and (b) above.
145. The project participants and the focal point designate one primary authorized signatory and one alternate authorized signatory. The signature of either the primary or alternate authorized signatory suffices for authenticating the project participant’s or the focal point’s consent or instruction(s).
146. The project participants do not include or refer to private contractual arrangements in an MoC.
147. The secretariat publishes the MoC on the JCM website following the registration of the project. The MoC is shared only among the project participants, the Joint Committee, the secretariat and the TPE involved in the JCM project. The secretariat makes sections 1 to 4 of the MoC without specimen signatures publicly available.

1.7.3. Submission of sustainable development implementation plan

1.7.3.1. Preparation of sustainable development and implementation plan

148. The project participants of a proposed JCM project prepare a draft sustainable development implementation plan (hereinafter referred to as “SDIP”), which describes the plan of contribution to sustainable development, using the latest version of that form in line with the “Joint Crediting Mechanism Guidelines for Developing Sustainable Development Implementation Plan and Report” (hereinafter referred to as “SDIP and SDIR Guidelines”), and submit the draft SDIP together with supporting documentation, as appropriate, to the Joint Committee through the secretariat at the time of the submission of the draft PDD in line with the paragraph 131 above.
149. The project participants may submit the draft SDIP to the Joint Committee through the secretariat, using the previous version of the “JCM Sustainable Development Implementation Plan Form” within the grace period of six (6) months from the date of publication of a new version. The Joint Committee does not accept the draft SDIP using the previous version after the grace period of six (6) months.
150. The secretariat notifies the receipt of the submission of the draft SDIP to the project participants by electronic means.
151. Upon notifying the receipt of the submission, the secretariat makes the draft SDIP publicly available through the JCM website for public inputs. The duration of call for public inputs on the draft SDIP is thirty (30) calendar days subsequent to the publication of the draft SDIP. The secretariat informs the project participants of the location of the draft SDIP on the JCM website and the opening and closing dates of the duration of call for public inputs.

1.7.3.2. Review of sustainable development and implementation plan

152. After closing the call for public inputs, the secretariat conducts a review of the draft SDIP within fourteen (14) calendar days.
153. During the review, the secretariat may interact with the project participants on specific issues regarding the SDIP.
154. The secretariat notifies the project participants by electronic means during the period of review specified in paragraph 152 above if potential negative impacts of the project on sustainable development are identified and an appropriate action plan is not described.
155. In case potential negative impacts of the project on sustainable development are identified and an appropriate action plan is not properly described during the period of review, the secretariat requests the project participants to revise the draft SDIP and resubmit it for review.
156. The draft SDIP is deemed positively reviewed if no potential negative impacts are identified or an appropriate action plan is properly described during the period of review.

1.7.3.3. Submission and treatment of public inputs

157. All stakeholders may submit inputs, in English, on the draft SDIP to the project participants and the secretariat through electronic means specified on the JCM website. The submitters of the inputs provide the name and contact details of the individual or organization on whose behalf the inputs are submitted. The secretariat checks the authenticity and relevance of this information in case of doubt.
158. The secretariat makes the inputs publicly available through the JCM website where the draft SDIP is displayed and removes those that the secretariat has determined to be unauthentic in line with paragraph 157 above.

1.7.4. Validation of a proposed JCM project

159. The TPE, in line with the “Joint Crediting Mechanism Guidelines for Validation and Verification” (hereinafter referred to as “Validation and Verification Guidelines”), validates the MoC and the proposed JCM project as described in the draft PDD, prepares a validation report using the latest version of the “JCM Validation Report Form” and sends the report to the project participants.
160. The TPE may send the validation report to the project participants using the previous version of the “JCM Validation Report Form” within the grace period of six (6) months from the date of publication of a new version. The validation report using the previous version after the grace period of six (6) months is not accepted by the Joint Committee.
161. Validation can be conducted simultaneously with verification.

1.8. Registration of project

1.8.1. Request for registration

1.8.1.1. Submission of request for registration

162. Project participants of a JCM project consult among themselves and both governments the credit allocation among the project participants of Japan, the project participants of (Partner Country), the Government of Japan and the Government of (*Partner Country*), taking into consideration their respective contribution to GHG emission reductions or removals.
163. The project participants, after receiving no objection to the PIN, a positive validation opinion by the TPE, and after the SDIP is positively reviewed by the secretariat, may request for registration of the proposed JCM project. When requesting for registration, the project participants submit the completed “JCM Project Registration Request Form” using the latest version of that form, the validated PDD and MoC, the validation report, the positively reviewed SDIP, the completed “JCM Credit Allocation Form” using the latest version of that form, and other supporting documents, as appropriate, by electronic means.

164. The project participants may request for registration of the proposed JCM project using the previous versions of the “JCM Project Registration Request Form” and the “JCM Credit Allocation Form” within the grace period of six (6) months from the date of publication of a new version. The Joint Committee does not accept the request using the previous version after the grace period of six (6) months.

1.8.1.2. Processing request for registration

165. The secretariat maintains a publicly available list of all submitted requests for registration through the JCM website.
 166. The secretariat notifies the receipt of the request for registration to the project participants by electronic means.
 167. Upon receiving the request for registration, the secretariat conducts a completeness check within seven (7) calendar days to determine whether the request for registration submission is complete.
 168. Upon completion of the completeness check, the secretariat notifies the project participants and the TPE of the result of the completeness check.

1.8.2. **Consideration of a proposed project**

169. The Joint Committee receives the validated PDD and MoC, the validation report and the positively reviewed SDIP by the secretariat and considers the proposed project.
 170. The Joint Committee may interact with the project participants on specific issues regarding the proposed project.
 171. The outcome of the consideration is as follows:
 (a) Registration of the proposed project;
 (b) Registration of the proposed project with revisions;
 (c) Rejection of the proposed project.
 172. The Joint Committee should complete the consideration within thirty (30) calendar days from the closing of the completeness check. If this is deemed not possible due to matters such as ongoing clarifications, then the secretariat notifies the project participants of the status of discussion within thirty (30) calendar days from the closing of the completeness check, and the Joint Committee should complete the consideration no later than sixty (60) calendar days from the closing of the completeness check.
 173. Upon positive result of the consideration, the Joint Committee decides the credit allocation and registration of the proposed JCM project.
 174. When the Joint Committee decides to register the proposed JCM project, the secretariat notifies each government, the project participants and the TPE of the registration and makes publicly available the relevant information including the credit allocation for the JCM project through the JCM website.
 175. The project participants may resubmit any proposed JCM project that has been assessed as incomplete by the secretariat or has been rejected by the Joint Committee. Such submission addresses the reasons for incompleteness stated by the secretariat or rejection stated by the Joint Committee.

1.9. Pre-issuance activities

1.9.1. **Preparation of monitoring report**

176. The project participants prepare a draft monitoring report in line with the applied methodology and the PDD and Monitoring Guidelines, and submit it together with supporting documentation to the TPE contracted by the project participants to perform verification of the monitored GHG emission reductions or removals.

1.9.2. **Verification of emission reductions or removals**

177. The TPE, in line with the Validation and Verification Guidelines, verifies the amounts of GHG emission reductions or removals on the basis of the monitoring report submitted by the project participants, prepares a verification report using the latest version of the “JCM Verification Report Form” and sends the report to the project participants which requested verification.
 178. The TPE may send the verification report to the project participants using the previous version of the “JCM Verification Report Form” within the grace period of six (6) months from the date of publication of a new version. The verification report using the previous version after the grace period of six (6) months is not accepted by the Joint Committee.
 179. Verification can be conducted simultaneously with validation.

1.9.3. **Sustainable development implementation report**

1.9.3.1. Preparation of sustainable development implementation report

180. The project participants prepare a sustainable development implementation report (hereinafter referred to as “SDIR”) which consists of a completed “JCM Sustainable Development Implementation Report Form” using the latest version of that form in line with the SDIP and SDIR Guidelines and the positively reviewed SDIP, and submit the SDIR together with supporting documentation, as appropriate, to the Joint Committee through the secretariat at the time of the submission of the draft monitoring report in line with the paragraph 176 above.
 181. The project participants may submit the SDIR to the Joint Committee through the secretariat, using the previous version of the “JCM Sustainable Development Implementation Report Form” within the grace period of six (6) months from the date of publication of a new version. The Joint Committee does not accept the SDIR using the previous version after the grace period

of six (6) months.

182. The secretariat notifies the receipt of the submission of the SDIR to the project participants by electronic means.
183. Upon receiving the SDIR, the secretariat conducts a completeness check within seven (7) calendar days. If the submission is deemed incomplete, the secretariat notifies the project participants of the reason.
184. Upon positive result of the completeness check, the Joint Committee conducts an evaluation of the SDIR within thirty (30) calendar days, including on-site visit where necessary.
185. During the evaluation, the secretariat may interact with the project participants on specific issues regarding the SDIR.
186. The secretariat notifies the project participants by electronic means during the period of evaluation specified in paragraph 184 above if negative impacts of the project on sustainable development are identified without appropriate description on the corrective action. The SDIR is deemed positively evaluated if no negative impacts are identified or appropriate description on the corrective action is properly addressed during the period of evaluation.
187. If negative impacts of the project on sustainable development are identified without appropriate description on the corrective action, the project participants may revise SDIR and re-submit it for re-evaluation as described in section 1.9.3.2 below.

1.9.3.2. Conditions resulting in the revision of SDIR

188. In case negative impacts of the project on sustainable development are identified without appropriate description on the corrective action, the project participants may submit the revised SDIR to the Joint Committee through the secretariat within sixty (60) calendar days from the date of notification by submitting the revised SDIR highlighting all revisions. The submission may be accompanied by additional documents which help explain the revisions.
189. The Joint Committee conducts re-evaluation of the revised SDIR within ten (10) calendar days.
190. The secretariat notifies the project participants by electronic means during the period of evaluation specified in paragraph 189 above if negative impacts of the project on sustainable development are identified without appropriate description on the corrective action.
191. If negative impacts of the project on sustainable development are identified without appropriate description on the corrective action, the project participants may repeat SDIR revision for re-evaluation as specified in paragraphs 188 to 190 above.

1.9.4. **Preparation of project implementation report**

192. The project participants prepare a project implementation report and submit it to the Joint Committee annually until the end of the operational lifetime of the project or the end of the crediting period, whichever comes first. When reporting to the Joint Committee, the project participants submit the completed “JCM Project Implementation Report Form” using the latest version of that form by electronic means.
193. The project participants may submit the report to the Joint Committee using the previous version of the “JCM Project Implementation Report Form” within the grace period of six (6) months from the date of publication of a new version. The Joint Committee does not accept the report using the previous version after the grace period of six (6) months.

1.10. Issuance of credits

1.10.1. **Request for issuance**

1.10.1.1. Submission of request for issuance

194. The project participants who wish to have credits issued open an account in the registry of the Government of Japan and/or the Government of (*Partner Country*) before requesting issuance of credits.
195. The project participants may request the Joint Committee to notify each government to issue credits to their respective accounts in the registry, only after the TPE verifies the amount of GHG emission reductions or removals. When requesting to notify each government to issue credits, the project participants submit the completed “JCM Credits Issuance Request Form” using the latest version of that form, including information on the allocation of credits among the project participants and both governments in tonnes of CO₂ equivalent in line with the credit allocation decided in paragraph 173, the verified monitoring report, the verification report, and the evaluated SDIR by electronic means.
196. The credit allocation decided by the Joint Committee may be revised when all the project participants and both governments consent to change.
197. The project participants may request the Joint Committee to notify each government to issue credits using the previous version of the “JCM Credits Issuance Request Form” within the grace period of six (6) months from the date of publication of a new version. The Joint Committee does not accept the request using the previous version after the grace period of six (6) months.

1.10.1.2. Processing request for issuance

198. The secretariat notifies the receipt of the request for issuance to the project participants by electronic means.
199. The secretariat conducts a completeness check within seven (7) calendar days to determine whether the request for issuance, including allocation of the credits among the project participants in tonnes of CO₂ equivalent, is complete.
200. Upon positive result of the completeness check, the Joint Committee decides to notify each government of the amount of credits to be issued.
201. Upon decision by the Joint Committee, the secretariat notifies each government, the project participants and the TPE of the

result.

1.10.1.3. Finalizing request for issuance

202. Upon notification by the secretariat, each government issues the amount of credits specified in the notification to respective accounts of project participants in the registry.
203. Each government notifies the issuance of credits to the Joint Committee through the secretariat.
204. The secretariat archives all the data of issuance of credits and makes them publicly available through the JCM website.

1.11. Renewal of crediting period

1.11.1. Assessment of validity of reference emissions of the applied methodology

205. The project participants, who selected a renewable crediting period of the registered JCM project and wish to renew its crediting period, evaluate the validity of the reference emissions of the applied methodology.
206. Reference emissions are deemed to have validity if five (5) years have not passed since the approval date or the date of last positive result decided by the Joint Committee on the validity of reference emissions in line with section 1.7.1.1 or section 1.11.1, of the approved methodology to be applied, which the latest version at the time of the submission of the request for renewal of crediting period or the previous version if the submission of the request for renewal of the crediting period is still within the grace period of the previous version for use.
207. If the reference emissions are not deemed to have validity in line with paragraph 206 nor to fulfill the requirements described in the Methodology Guidelines, the project participants proceed to revision of an approved methodologies applied in line with Section 2.2.1 below.
208. When the reference emissions are not deemed to have validity in line with paragraph 206 but to fulfill the requirements described in the Methodology Guidelines, the project participants submit a request with relevant evidence of their evaluation to the Joint Committee through the secretariat for assessment on validity of reference emissions, using the latest version of “JCM Assessment of reference emissions request form”.
209. The secretariat conducts a completeness check of the submitted request within seven (7) calendar days to determine whether the submitted request is complete.
210. Upon completion of the completeness check, the secretariat notifies the project participants of the result of the completeness check.
211. Upon positive result of the completeness check, the Joint Committee assesses the submission in line with the Methodology Guidelines and decides the validity of reference emissions of the approved methodology.
212. Upon positive result on its validity of reference emissions of the approved methodology by the Joint Committee, the project participants update its PDD for renewal of crediting period and proceed to the validation process.
213. The project participants may request to revise the approved methodology in line with Section 2.2.1 below when the assessment by the Joint Committee does not complete in a positive result.

1.11.2. Validation of updated PDD for renewal of crediting period

214. The project participants, who selected a renewable crediting period of the registered JCM project and wish to renew its crediting period, update its PDD applying the approved methodology, of which reference emissions are deemed to have validity in line with paragraph 206 or of which the validity of reference emissions is positively completed by the Joint Committee, or applying the revised approved methodology, in line with Section 1.11.1 above.
215. When requesting the renewal of crediting period, the project participants submit the updated PDD to the TPE contracted by the project participants to perform validation of the JCM project and to the Joint Committee through the secretariat for public inputs. Publication of the updated PDD is carried out in the same procedure as described in Section 1.7.1 above.
216. The TPE, in line with the Validation and Verification Guidelines validates the JCM project as described in the updated PDD and the MoC as necessary in line with Section 1.7.4 above.

1.11.3. Request for renewal of crediting period

1.11.3.1. Submission of request for renewal of crediting period

217. The project participants, after receiving a positive validation opinion by the TPE submit a request for renewal of crediting period of the registered JCM project using the latest version of the “JCM Renewal of crediting period request form” together with the updated PDD, the validation report and a completed “JCM Credit Allocation Form” using the latest version of that form to the secretariat. Such a submission is made no earlier than two hundred and seventy (270) days prior to, but no later than one year after, the expiry of the crediting period.

1.11.3.2. Processing of request for renewal

218. The secretariat processes a submission in line with Section 1.8.1 above.

1.11.3.3. Finalizing request for renewal

219. Upon positive result of the completeness check, the Joint Committee decides to renew the crediting period of the JCM project.

When the Joint Committee decides to renew the crediting period of the JCM project, the same procedure is carried out as described in paragraph 174 above.

2. SPECIFIC PROCEDURES

2.1. No objection to a planned project

2.1.1. No objection to a planned project

2.1.1.1. Processing no objection to a planned project

220. If the secretariat, during the completeness check of a PIN, identifies issues of an editorial nature, it requests project participants by electronic means to submit the missing information. In this case, project participants submit the requested information within seven (7) calendar days of receipt of the request. If project participants do not submit the requested information by this deadline, the PIN is deemed incomplete. The secretariat conducts the completeness check within five (5) calendar days from the date of the receipt of the requested information.
221. If the PIN does not meet the requirements of the completeness check, the secretariat communicates the underlying reasons to the project participants. In this case, the project participants may re-submit the revised PIN as described in paragraph 82 and 83 above.

2.2. Approval of methodologies

2.2.1. Revision of an approved methodology

222. Methodology proponents may request the Joint Committee through the secretariat to revise an approved methodology by submitting the completed "JCM Approved Methodology Revision Request Form" using the latest version of that form and the proposed revised methodology highlighting all proposed changes.
223. The methodology proponents may request the Joint Committee for the revision of an approved methodology using the previous version of the "JCM Approved Methodology Revision Request Form" within the grace period of six (6) months from the date of publication of a new version. The Joint Committee does not accept the request using the previous version after the grace period of six (6) months.
224. The submission may be accompanied by additional documents which help explain the proposed revision. The Joint Committee may request the methodology proponents to submit additional documents including a draft PDD to which the proposed revised methodology is applied.
225. The secretariat notifies the receipt of the submission to the methodology proponents by electronic means.
226. Methodologies may also be revised under the initiative of the Joint Committee.
227. The secretariat conducts a completeness check of the submission in the same procedure as described in section 1.5.2.
228. In parallel with the completeness check, the secretariat also assesses the nature and complexity of the proposed revision and classify them as follows:
 - (a) Substantive revision proposal: Substantive changes to the approved methodology including changes in eligibility criteria, calculation and monitoring methods and parameters; or
 - (b) Editorial revision proposal: Correction of misstatements and editorial revisions to improve the clarity of the approved methodology.
229. Upon completion of the completeness check and the assessment of the proposed revision by the secretariat, all substantive revision proposals referred to in paragraph 228(a), including those under the initiative of the Joint Committee, are subject to public inputs procedure as described in section 1.5.3.
230. Consideration of the substantive revision proposals is conducted in the same procedure as described in paragraphs 106 to 115.
231. The secretariat makes publicly available all approved revised methodologies through the JCM website within five (5) calendar days from the date of decision by the Joint Committee.
232. Project participants may apply the approved revised methodology in projects seeking validation after the date on which the revised version is approved.
233. Upon completion of the completeness check and the assessment of the proposed revision by the secretariat, all editorial revision proposals referred to in paragraph 228(b), including those under the initiative of the Joint Committee, are reflected as appropriate by the secretariat after approval by the Joint Committee. The secretariat makes the revised methodology publicly available through the JCM website.
234. The revision of an approved methodology has no effect on projects which have started the public inputs for draft PDDs applying the previous version of the revised methodology.

2.2.2. Putting on hold of an approved methodology

235. In case new or better comprehension of scientific evidence indicates that emission reductions may be overestimated based on the approved methodology, or there are identified inconsistencies, errors and/or ambiguities in the approved methodology, the Joint Committee may put on hold an approved methodology at any time. In this case, the Joint Committee decides to either:
 - (a) Put on hold the approved methodology with immediate effect. In this case, project participants do not submit any draft PDD for public inputs or any request for registration of a project applying the methodology, from the day following the date of publication of the Joint Committee's decision through the JCM website; or

- (b) Put on hold the approved methodology with a grace period of twenty-eight (28) calendar days. In this case, project participants do not submit any request for registration of a project applying the methodology any more than twenty-eight (28) calendar days following the date of publication of the Joint Committee's decision through the JCM website.

2.3. Pre-registration activities

2.3.1. Conditions resulting in the revision of project design document

- 236. The project participants may submit a draft PDD to request for registration applying the previous version of an approved methodology within the grace period of eight (8) months from the date of publication of revised version except when the methodology is revised following the process described in paragraph 235 above. If the project participants have submitted a draft PDD applying the previous version of an approved methodology to the TPE for validation and to the Joint Committee through the secretariat for public inputs but do not submit request for registration within the grace period, they revise the draft PDD applying the new version of the methodology and submit it to the TPE for validation and to the Joint Committee through the secretariat for public inputs, notifying the reference number which has already been issued to the proposed JCM project.
- 237. If the project participants wish to change the approved methodology applied in the draft PDD that has already been published for public inputs, they revise the draft PDD and submit the revised draft PDD to the TPE for validation and to the Joint Committee through the secretariat for public inputs, notifying the reference number which has already been issued to the proposed JCM project.

2.4. Registration of project

2.4.1. Request for registration

2.4.1.1. Processing request for registration

- 238. If the secretariat, during the completeness check, identifies issues of an editorial nature, it requests project participants by electronic means, copying the TPE, to submit the missing or revised documents and/or information. In this case, project participants submit the requested documents and/or information within seven (7) calendar days of receipt of the request. If project participants do not submit the requested documents and/or information by this deadline, the request for registration is deemed incomplete. The secretariat conducts the completeness check within seven (7) calendar days from the date of the receipt of the requested documents and/or information.
- 239. If the request for registration does not meet the requirements of the completeness check, the secretariat communicates the underlying reasons to the project participants and the TPE, and makes them publicly available through the JCM website. In this case, the project participants may re-submit the request for registration with revised documentation as described in paragraph 163 above.
- 240. If the secretariat notifies the project participants that the request for registration is incomplete, in line with paragraph 239 above, more than forty-five (45) calendar days after the submission of the request for registration, and the request for registration was submitted more than forty-five (45) calendar days prior to the expiry of the grace period of the previous version of a methodology, then for re-submission purposes, the project participants are granted an extension of the validity of the methodology by the number of calendar days in excess of the forty-five (45) calendar days elapsed before the notification on incompleteness is made.

2.4.1.2. Rejecting request for registration

- 241. If the Joint Committee decides to reject the request for registration, the secretariat notifies each government, the project participants and the TPE of the rejection and its reasons and makes publicly available the decision with its reasons through the JCM website.
- 242. In the case of paragraph 241 above, the project participants may re-submit the request for registration with revised documentation in line with section 1.8.1 if the reasons for the rejection can be addressed by means of a validation report revised by the TPE, based on a revised PDD as appropriate. In this case, the project participants justify that the re-submission falls under such case.

2.5. Post-registration activities

2.5.1. Changes to registered JCM project

- 243. When the project has been changed from the registered PDD, methodology and/or positively reviewed SDIP, those changes are classified into the following:
 - (a) Changes determined by the TPE that do not prevent the use of the applied methodology;
 - (b) Changes identified by the project participants prior to verification or by the TPE during verification that would prevent the use of the applied methodology;
 - (c) Changes identified by the project participants or determined by the TPE that prevent the use of the applied methodology;
 - or
 - (d) Changes identified by the project participants that would affect the applicability of the reviewed SDIP.
- 244. If changes are classified into paragraph 243(a), the project participants revise the PDD and submit it for the first issuance request subsequent to the revision.

245. If changes are classified into paragraph 243(b) or 243(d), the project participants proceed with the process described in sections 2.5.1.1 and 2.5.1.2 below.
246. If changes are classified into paragraph 243(c), the project participants withdraw the project in line with section 2.7. The project participants may re-submit a request for registration for the withdrawn project in line with section 1.7.1.
- 2.5.1.1. Submission of request for approval of changes
247. The project participants obtain approval of changes by the Joint Committee prior to the submission of the request for issuance of credits in cases described in paragraphs 243(b) and 243(d).
248. To obtain approval from the Joint Committee for the changes that would prevent the use of methodology, the project participants submit a completed “JCM Post-Registration Changes Request Form” using the latest version of that form and a revised PDD to the secretariat by electronic means.
249. The project participants may request the Joint Committee to approve the changes using the previous version of the “JCM Post-Registration Changes Request Form” within the grace period of six (6) months from the date of publication of a new version. The Joint Committee does not accept the request using the previous version after the grace period of six (6) months.
250. To obtain approval from the Joint Committee for the changes that would affect the applicability of the reviewed SDIP, the project participants submit a completed “JCM Post-Registration Changes Request Form”, a revised SDIP and a revised PDD where necessary to the secretariat by electronic means.
- 2.5.1.2. Processing request for approval of changes
251. The secretariat prepares and maintains a publicly available list of all submitted requests for approval of changes through the JCM website.
252. Upon receipt of the request for approval of changes, the secretariat conducts within seven (7) calendar days the completeness check to determine whether the request for approval of changes is complete.
253. Upon positive result of the completeness check of the request for approval of changes, the secretariat, within fourteen (14) calendar days, prepares and sends to the Co-Chairs a summary note on the request with a recommendation on the course of action, or with a notification that the case will be considered by the Joint Committee.
254. If the secretariat, during the preparation of the summary note, identifies issues that require clarifications from project participants, it requests the project participants to submit revised documents and/or information to clarify the issues within fourteen (14) calendar days of the notification of the request by the secretariat. In this case, the secretariat, notwithstanding the provision in paragraph 253 above, finalizes the summary note and sends it to the Co-Chairs within fourteen (14) calendar days of receipt of the requested documents and/or information from the project participants. If the project participants do not submit the requested documents and/or information by this deadline, the secretariat suspends the process for the request for approval of changes.
255. If the secretariat, during the preparation of the summary note, identifies issues that require inputs from a relevant expert, it seeks guidance from the expert. In this case, the secretariat, notwithstanding the provisions in paragraphs 253 and 254 above, finalizes the summary note and sends it to the Co-Chairs within fourteen (14) calendar days of receipt of the inputs from the expert.
256. Upon confirmation of the summary note by the Co-Chairs, the summary note is distributed to the Joint Committee through the secretariat, and the Joint Committee decides whether to approve the request.
257. Once a decision has been made by the Joint Committee, the secretariat informs the project participants of the decision and any guidance provided by the Joint Committee as applicable, and makes the decision and guidance publicly available through the JCM website.
258. If the request for approval of changes is approved with guidance which requests further revision of the revised PDD and/or the revised SDIP by the Joint Committee, the project participants revise the PDD and/or the SDIP in line with the guidance and submit to the Joint Committee through the secretariat the revised PDD and/or the revised SDIP reflecting the guidance. The secretariat makes the revised PDD publicly available through the JCM website as the registered PDD. This version of the registered PDD is applied for future requests for issuance of credits.
259. If the request for approval of changes is approved without guidance, the secretariat makes the revised PDD publicly available through the JCM website as the registered PDD. This version of the registered PDD is applied for future requests for issuance of credits.
260. If the request for approval of changes is not approved, the project participants withdraw the project in line with section 2.7 or follow one of the procedures described in the subparagraphs (a) to (c) below. In either procedure, the project participants notify the reference number which has already been issued to the registered JCM project to the TPE and the secretariat as applicable:
- (a) In cases described in paragraph 243(b), the project participants revise the PDD and the SDIP as necessary, submit a revised draft PDD to the TPE for validation and to the secretariat for public inputs, and submit a revised SDIP to the secretariat for a review as applicable;
 - (b) In cases described in paragraph 243(d) and the PDD is needed to be revised, the project participants revise the PDD and the SDIP, submit a revised draft PDD to the TPE for validation and to the secretariat for public inputs, and submit a revised SDIP to the Joint Committee for a review; or
 - (c) In cases described in paragraph 243(d) and the PDD is not needed to be revised, the project participants revise the SDIP and submit a revised SDIP to the Joint Committee through the secretariat for a review.

2.5.2. Changes to registered modalities of communication

2.5.2.1. General requirements

261. Project participants of the JCM project request changes to the contents of the registered MoC to the secretariat as soon as possible after the changes become effective.
262. The secretariat requests a new submission of a MoC whenever the secretariat identifies inconsistencies or inaccuracies in the registered MoC.
263. In case of requesting for changes to the contents of the registered MoC, project participants submit a new MoC using the latest version of the “JCM Modalities of Communication Statement Form” to the secretariat by electronic means.
264. Project participants may request for changes to the contents of the registered MoC by using the previous version of the “JCM Modalities of Communication Statement Form” within the grace period of six (6) months from the date of publication of a new version. The secretariat does not accept the previous version after the grace period of six (6) months.
265. Project participants who submit a new MoC ensure that:
 - (a) Supporting documentation, including powers of attorney, or extracts from board meeting minutes or company association documentation, or extracts/certificates from national company registries that cannot be verified online, is dated or notarized within two (2) years from the time of submission of a request for change to established modalities of communication. This time limitation does not apply to copies of national personal identity documents;
 - (b) To the extent possible, changes applicable to more than one JCM project or multiple changes affecting the same JCM project are consolidated in a single form.
266. The legal representative of a project participant may sign on behalf of the authorized signatories if the primary and alternate authorized signatories of the project participant concerned are no longer available.
267. Legal representatives signing on behalf of the project participants provide written evidence that they are authorized to sign on behalf of the respective entities.
268. The secretariat may request additional clarification and/or documentation if submissions do not clearly provide evidence.
269. The secretariat displays the updated MoC including its annex 1 as necessary and their effective dates on the JCM website in line with paragraph 147.

2.5.2.2. Voluntary changes to focal point

270. Any of the project participants for a registered JCM project may request for changes on the designation of the focal point for any reason and at any time by submitting a new MoC signed by all project participants using the latest version of the “JCM Modalities of Communication Statement Form” to the secretariat by electronic means.
271. Project participants may request for changes on the designation of the focal point by using the previous version of the “JCM Modalities of Communication Statement Form” within the grace period of six (6) months from the date of publication of a new version. The secretariat does not accept the previous version after the grace period of six (6) months.

2.5.2.3. Changes to project participants

272. If the project participants of a registered JCM project have changed after the registration of the project, project participants submit a completed annex 1 of the “JCM Modalities of Communication Statement Form” for each of the following changes:
 - (a) Addition of a project participant;
 - (b) Changes related to entity names/legal status;
 - (c) Withdrawal of a project participant. If a project participant has ceased operations due to bankruptcy or other reasons and is unable to sign the “JCM Modalities of Communication Statement Form”, the submission is accompanied by documented evidence of the cessation;
 - (d) Changes related only to contact details and specimen signatures.
273. A project participant added to a registered JCM project accepts the existing MoC unless a new MoC is submitted simultaneously.

2.6. Issuance of credits

2.6.1. Request for issuance

2.6.1.1. Processing request for issuance

274. If the secretariat, during the completeness check, identifies issues of an editorial nature, it requests the project participants by electronic means, copying the TPE, to submit the missing or revised documents and/or information. In this case, the project participants submit the requested documents and/or information within seven (7) calendar days of receipt of the request. If the project participants do not submit the requested documents and/or information by this deadline, the request for issuance is deemed incomplete. The secretariat conducts the completeness check within seven (7) calendar days from the date of the receipt of the requested documents and/or information.
275. If the request for issuance does not meet the requirements of the completeness check, the secretariat communicates its result and the underlying reasons to the project participants and the TPE, and makes them publicly available through the JCM website. In this case, the project participants may re-submit the request for issuance with revised documentation.

2.6.1.2. Rejecting request for issuance

276. If the Joint Committee decides to reject the request for issuance, the secretariat notifies the project participants and the TPE of the rejection and updates the information accordingly on the JCM website immediately after the decision-making.
277. The Joint Committee makes the reasons for the rejection publicly available through the JCM website.
278. In the case of paragraph 276 above, the project participants may re-submit the request for issuance with revised documentation in line with section 1.10.1 if the reasons for the rejection can be addressed by means of a verification report revised by the TPE, based on a revised monitoring report as appropriate. In this case, the project participants justify that the re-submission falls under such case.

2.7. Withdrawal**2.7.1. Submission of request for withdrawal**

279. The project participants may voluntarily withdraw a proposed or registered JCM project at any time. In such case, the project participants submit a completed “JCM Project Withdrawal Request Form” using the latest version of that form to the Joint Committee through the secretariat by electronic means.
280. For the following cases, the project participants submit a completed “JCM Registration Request Withdrawal Form” using the latest version of that form to the Joint Committee through the secretariat by electronic means:
- (a) The project participants voluntarily wish to withdraw a request for registration;
 - (b) The TPE has revised its validation opinion based on new insights or information and has notified it to the project participants.
281. For the following cases, the project participants submit a completed “JCM Issuance Request Withdrawal Form” using the latest version of that form to the Joint Committee through the secretariat by electronic means:
- (a) The project participants voluntarily wish to withdraw a request for issuance for the specified monitoring period;
 - (b) The TPE has revised its verification report based on new insights and has notified it to the project participants.
282. In the case of paragraphs 279, 280 and 281 above, the project participants may use the previous version of the “JCM Project Withdrawal Request Form”, “JCM Registration Request Withdrawal Form” or “JCM Issuance Request Withdrawal Form” within the grace period of six (6) months from the date of publication of a new version. The Joint Committee does not accept the previous version after the grace period of six (6) months.

2.7.2. Processing request for withdrawal

283. Upon receipt of the request for withdrawal, the secretariat confirms the documents submitted.
284. Upon confirmation by the secretariat:
- (a) For a withdrawal of a project, the project is marked as “withdrawn” on the JCM website;
 - (b) For a withdrawal of a request for registration, the request for registration is marked as “withdrawn” on the JCM website;
 - (c) For a withdrawal of a request for issuance, the request for issuance for the specified monitoring period is marked as “withdrawn” on the JCM website.

Joint Crediting Mechanism Guidelines for Developing Proposed Methodology

CONTENTS

1. Scope and applicability	24
2. Terms and definitions	24
3. Key concepts	24
3.1. Reference emissions	24
3.2. Eligibility criteria	24
4. General Guidelines.....	24
5. Instructions for completing the Proposed Methodology Form.....	25
6. Instructions for completing the Proposed Methodology Spreadsheet.....	30
Annex I. Sectoral Scopes for the JCM	32

1. Scope and applicability

285. Joint Crediting Mechanism Guidelines for Developing Proposed Methodology (hereinafter referred to as “these Guidelines”) are intended to assist each government or project participants (hereinafter referred to as “methodology proponents”) in preparing proposed methodologies for the Joint Crediting Mechanism (hereinafter referred to as “JCM”) (hereinafter referred to as “proposed methodologies”).
286. These Guidelines are also to be referred to by the Joint Committee in developing and assessing proposed methodologies.
287. These Guidelines describe standards which are requirements to be met, except guidance indicated with terms “should” and “may” as defined in paragraph 289 below.
288. Submission and subsequent assessment of a proposed methodology are conducted in line with the procedure delineated in Joint Crediting Mechanism Project Cycle Procedure.

2. Terms and definitions

289. The following terms apply in this Guidelines:
- “Should” is used to indicate that among several possibilities, one course of action is recommended as particularly suitable;
 - “May” is used to indicate what is permitted.
290. Terms in the Proposed Methodology Form are defined in JCM Glossary of Terms available on the JCM website.

3. Key concepts

3.1. Reference emissions

291. In the JCM, emission reductions to be credited are defined as the difference between reference emissions and project emissions.
292. The reference emissions are calculated to be below business-as-usual (BaU) emissions which represent plausible emissions in providing the same outputs or service level of a proposed JCM project in (*Partner Country*).
293. The reference emissions are established in a manner that the proposed project contributes to the achievement of the latest nationally determined contribution of (*Partner Country*) under the Paris Agreement.

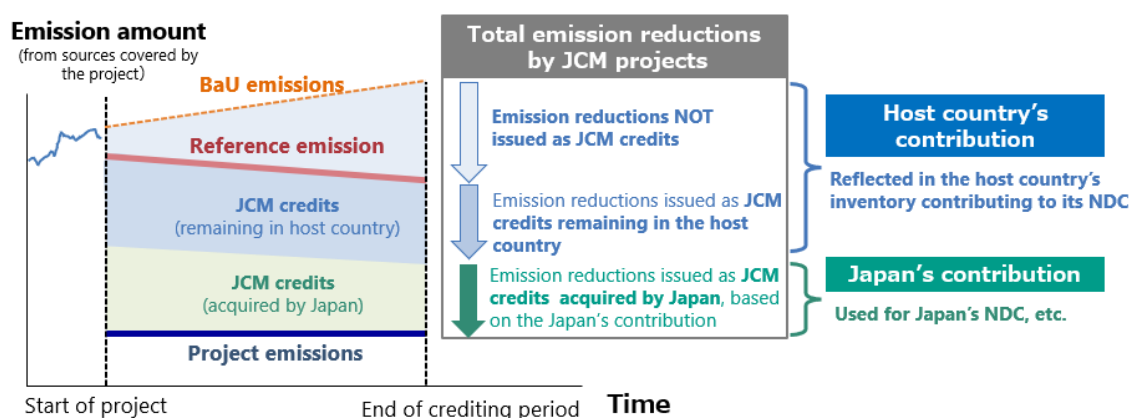

Figure: Indicative diagram of the relationship between the BaU emissions, reference emissions and project emissions

3.2. Eligibility criteria

294. Eligibility criteria in proposed methodologies contain the following:
- Requirements for the project in order to be registered as a JCM project.
 - Requirements for the project to be able to apply the approved methodology.

4. General Guidelines

295. Methodology proponents prepare the proposed methodology by filling in the Proposed Methodology Form and the Proposed Methodology Spreadsheet, attached to these Guidelines.
296. These Guidelines, the Proposed Methodology Form and the Proposed Methodology Spreadsheet may be obtained electronically from the JCM website.
297. The Proposed Methodology Form and the Proposed Methodology Spreadsheet are completed in English language.
298. Methodology proponents provide supporting documents to justify key logical and quantitative assumptions regarding the choice of eligibility criteria, default values and establishment of reference emissions.
299. The Joint Committee develops the Proposed Methodology Form and the Proposed Methodology Spreadsheet and may revise them if necessary.
300. The Proposed Methodology Form is not altered, that is, is completed without modifying its format, font, headings. If sections of the Proposed Methodology Form are not applicable, it is explicitly stated that the section is left blank on purpose.

301. The Proposed Methodology Spreadsheet enables calculation of GHG emission reductions automatically through inputting values by project participants. The Proposed Methodology Spreadsheet consists of the following:
- An Input Sheet containing all the parameters to be monitored *ex post*, project-specific parameters to be fixed *ex ante* by the project participants (e.g. historical data) as well as the default factors which can be changed by the project participants. For each parameter, the methodology proponents fill in all the required fields, except for those of the inputted values;
 - A Calculation Process Sheet containing all the default values which cannot be changed by the project participant, calculation process to derive reference emissions and project emissions, and the resulting emission reductions.
302. The proposed methodology:
- Describes the procedures in a manner that is sufficiently explicit to enable the methodology to be used, be applied to projects unambiguously, and be reproduced by a third party;
 - Is possible for projects following the methodology to be subjected to JCM validation and/or verification;
 - Includes all algorithms, formulae, and step-by-step procedures needed to apply the methodology and validate the project, i.e., calculating reference emissions and project emissions;
 - Provides instructions for making any logical or quantitative assumptions that are not provided in the methodology and is made by the methodology user;
 - Avoids the intentional increase of credits caused by perverse incentives (e.g. when an increase in output is triggered by incentive to increase credits).
303. The presentation of values in the Proposed Methodology Form and the Proposed Methodology Spreadsheet should be in international standard format (e.g. 1,000 representing one thousand and 1.0 representing one). The units used should be accompanied by their equivalent S.I. units/norms (thousand/million) as part of the requirement to ensure transparency and clarity.

5. Instructions for completing the Proposed Methodology Form

Instructions for completing the Proposed Methodology Form are provided below. A hypothetical proposed methodology on building energy management systems (BEMS) is inserted to enhance the clarity of these Guidelines. This methodology is purely indicative and does not imply that the methodology is to be adopted.

Cover sheet of the Proposed Methodology Form	
Form for submitting the proposed methodology	
Host Country	<i>(Partner Country)</i>
Name of the methodology proponents submitting this form	Energy Management System Japan Ltd.
Sectoral scope(s) to which the Proposed Methodology applies	3. Energy demand
Title of the proposed methodology, and version number	Improving the Efficiency of Energy Use with Building Energy Management System (BEMS) Version 01.0
List of documents to be attached to this form (please check):	<input type="checkbox"/> The attached draft JCM-PDD: <input checked="" type="checkbox"/> Additional information 1) Catalog of adopted technology: BEMS 2) Regulation for energy efficiency of commercial buildings. 3) Feasibility studies and technical reports
Date of completion	01/04/2021

- Methodology proponents should submit the proposed methodology to the Joint Committee which is established by the Government of Japan and (Partner Country).
- The methodology proponents are each government, project participants, or the Joint Committee.
- Please identify sectoral scope(s) according to the JCM sectoral scope(s) listed in Annex I.
- Please indicate the following: (a) The title of the proposed methodology; (b) The version number of the document. Please provide an unambiguous title for the proposed methodology. The title should reflect the project types to which the methodology is applicable. Do not use project-specific titles.
- If the methodology proponents have attached additional information, please provide description of the documents.
- Fill in the date of completion in DD/MM/YYYY.

History of the proposed methodology

Version	Date	Contents revised
01.0	01/04/2021	First edition

- *If the methodology proponents revise a previously submitted methodology, please provide date of revision in DD/MM/YYYY as well as a brief summary of revision.*

A. Title of the methodology

Improving the Efficiency of Energy Use with Building Energy Management System (BEMS) Version 01.0

- *Please indicate the following: (a) The title of the proposed methodology; (b) The version number of the document. Provide an unambiguous title for the proposed methodology. The title should reflect the project types to which the methodology is applicable. Do not use project-specific titles.*
- *Please include the GHG emission reduction measures (e.g. technology, product, or service) adopted.*

B. Terms and definitions

Terms	Definitions
BEMS	BEMS is a computer system designed to recognize the status of energy use within indoor environments in commercial buildings and so forth using; measurement/gauging, control, and monitoring devices; analysis, diagnosis, and data storage equipment in an attempt to “control” energy consuming operations of equipment and facilities in these structures. Furthermore, if the system is utilized for “visualization” only, it is not to be directly used for emission reductions. Therefore, such project is not to be included in this methodology

- *Please provide definitions of key terms that are used in the proposed methodology.*

C. Summary of the methodology

Items	Summary
GHG emission reduction measures	Building energy management system (BEMS) that improves the efficiency of energy consumption for existing buildings by monitoring and regulating electricity and fuel consumption.
Calculation of reference emissions	Reference emissions are calculated on the basis of project emissions derived from monitored fuel and electricity consumption, under the assumption that certain percentage of energy consumption is decreased through introduction of BEMS. The BaU scenario assumes that BEMS will not be introduced in (Partner Country), which is justified since there are currently no plans to introduce BEMS. In the methodology, the rates of emission reductions through various BEMS measures are fixed at a rate lower than those commonly observed.
Calculation of project emissions	Project emissions are calculated on the basis of monitored electricity and fuel consumption.
Monitoring parameters	Electricity and fuel consumption are monitored.

- *Please summarize the key elements of the proposed methodology, including brief description on:*
 - *GHG emission reduction measures;*
 - *How the proposed methodology calculates the reference emissions;*
 - *How the proposed methodology calculates the project emissions;*
 - *Key monitoring parameters and methods.*

D. Eligibility criteria

This methodology is applicable to projects that satisfy all of the following criteria.

Criterion 1	Energy Management System is to be introduced in already existing buildings.
Criterion 2	The operation and control of equipment and facilities to reduce energy consumption for indoor environments are to be carried out by Energy Management System itself, not just upgrading equipment for energy consumption.
Criterion 3	Be able to identify all energy consumption in the building(s) having equipment controlled by Energy Management System.

- Eligibility criteria are those that can be examined objectively.
- Eligibility criteria include:
 - Characteristics to identify the measures (e.g. technology, product, or service) applied to the methodology;
 - Conditions that are necessary in order to enable robust calculation of GHG emission reductions by the algorithm contained in the methodology, e.g. the situation before the implementation of the measure, in cases where reference emissions are calculated on the basis of historical performance of the facility.
- Eligibility criteria should be, to the extent possible, those that can be ascertained upon validation, i.e. eligibility criteria should avoid those which need to be monitored ex post. For example, actual performance of a measure should not be included as eligibility criteria, since it is not certain at the validation whether the stated performance can be achieved. On the other hand, performance as defined by nameplate figures can be included as eligibility criteria since it can be readily checked upon validation.
- Eligibility criteria may be represented by:
 - Certain technology (e.g. geothermal power generation);
 - Certain technology with a design efficiency or performance indicator above a certain threshold (e.g. a power plant with a thermal efficiency above X%);
 - Certain sector to which the measure is applied.

E. Emission Sources and GHG types

The emission sources include all the following GHG emission sources and GHG types in the building to which BEMS is applied.

Reference emissions	
Emission sources	GHG types
Electricity consumption by lighting	CO ₂
Electricity consumption by air conditioner	CO ₂
Diesel fuel consumption by boiler	CO ₂
Electricity consumption by fan	CO ₂
Electricity consumption by ICT equipment	CO ₂
N/A	N/A
N/A	N/A
Project emissions	
Emission sources	GHG types
Electricity consumption by lighting	CO ₂
Electricity consumption by air conditioner	CO ₂
Diesel fuel consumption by boiler	CO ₂
Electricity consumption by fan	CO ₂
Electricity consumption by ICT equipment	CO ₂
N/A	N/A
N/A	N/A

- Please identify all GHG emissions by sources that are significant and reasonably attributable to the JCM project regardless of its emissions being inside or outside the project boundary (i.e., physical delineation and/or geographical area of the JCM project).
- If deemed appropriate, please explain whether any sources related to the reference emissions or the project emissions have been excluded, and if so, justify their exclusion.
- Upstream emissions may be excluded unless they are deemed to be significant.
- If significant GHG emissions outside the project boundary that are not covered in a corresponding methodology are observed, the methodology is revised to address such emissions. Significant GHG emissions are those which result in more than five (5) percent of emission reductions of a JCM project based on the concept of materiality in line with ISO 14064-3.

F. Establishment and calculation of reference emissions

F.1. Establishment of reference emissions

Reference emissions are calculated on the basis of project emissions derived from monitored fuel and electricity consumption, under the assumption that certain percentage of energy consumption is decreased through introduction of BEMS.

The BaU emissions assume the emissions when BEMS will not be introduced in (*Partner Country*), which is justified since there are currently no plans to introduce BEMS.

F.2. Calculation of reference emissions

$$RE_p = (PEC_p * EF_{e,p} + \sum(PFC_{i,p} * NCV_{i,p} * EF_{CO_2,i,p})) / (100\% - EER_j)$$

RE_p	Reference CO ₂ emissions during the period p [tCO ₂ /p]
PEC_p	Project electricity consumption by applicable equipment during the period p [MWh/p]
$EF_{e,p}$	CO ₂ emissions factor of electricity during the period p [tCO ₂ /MWh]
$PFC_{i,p}$	Project consumption of fossil fuel i of the applicable equipment during the period p [kl, t, 1000 Nm ³ /p]
$NCV_{i,p}$	Net calorific value of fossil fuel i (diesel, kerosene, natural gas, etc.) during the period p [GJ/kl, t, 1000 Nm ³] *Any default value (XX GJ/kl, t, 1000 Nm ³) or specific value for the project that the project participants measure is available.
$EF_{CO_2,i,p}$	CO ₂ emissions factor of fossil fuel i (diesel, kerosene, natural gas, etc.) during the period p [tCO ₂ /GJ]
EER_j	Percentage of improvement in energy consumption efficiency [%] for building type j using BEMS
	Office building VV%
	Commercial building WW%
	Hotel XX%
	Hospital YY%
	Other ZZ%

- Please provide only one procedure for establishing reference emissions, which, in the view of the methodology proponent, represents plausible emissions in providing the same outputs or service level of the proposed JCM project in (Partner Country).
- Reference emissions should be established, taking into account the following:
 - If the reference emissions are defined by multiplying an emission factor and an output, the output should be identical to or less than the monitored output of the project.
 - The reference emissions should comply with all applicable regulations of (Partner Country).
 - The reference emissions are established in a manner that the proposed project contributes to the achievement of the latest nationally determined contribution (NDC) of (Partner Country) under the Paris Agreement.
- Please provide a description on how the reference emissions are derived. Provide also a description of how and why the reference emissions are below the BaU emissions.
 - * Rationale and justification for setting reference emissions are to be explained in additional information attached to a proposed methodology at the time of submission.
- Reference emissions may be derived from:
 - The latest NDC of (Partner Country);
 - The current situation and performance;
 - Average historical performance;
 - Performance of similar products and technologies which compete with the project technology;
 - Legal requirements;
 - Voluntary standards and targets;
 - Best available technology of (Partner Country).
- Please elaborate how the reference emissions contribute to the achievement of the latest NDC of (Partner Country) (e.g. identification of sectors covered by the NDC, explanation of how the proposed methodology achieves emission reductions in the identified sector.)
- Please elaborate the method to calculate the reference emissions. Please be specific and complete, so that the procedure can be carried out in an unambiguous way, replicated, and subjected to assessment and verification:
 - Please explain the underlying rationale for the method to calculate (e.g. marginal vs. average, etc.);
 - Please use consistent variables, equation formats, subscripts, etc.;
 - Please number all equations in the Proposed Methodology Form;
 - Please define all variables, with units indicated;
 - Please justify the conservativeness of the method to calculate.
- Please elaborate all parameters, coefficients, and variables used in the calculation of reference emissions:
 - For those values that are provided in the methodology:
 - Please clearly indicate the precise references from which these values are taken (e.g. official statistics, IPCC Guidelines, commercial and scientific literature, (Partner Country)'s NDC);
 - Justify the conservativeness of the values provided.
 - For those values that are to be provided by the project participants, please clearly indicate how the values are to be selected and justified, for example, by explaining:
 - What types of sources are suitable (official statistics, expert judgment, proprietary data, IPCC Guidelines, commercial and scientific literature, (Partner Country)'s NDC, etc.);
 - The vintage of data that is suitable;
 - What spatial level of data is suitable (local, regional, national, international);
 - How conservativeness of the values is to be ensured.

- For all data to be monitored or recorded by the project participants, please specify the procedures to be followed if expected data are unavailable. For instance, the methodology could point to a preferred data source, and indicate a priority order for use of additional data and/or fall back data sources to preferred sources (e.g. private, international statistics, etc.).
- Please note any parameters, coefficients, variables, etc. that are used to calculate reference emissions but should be obtained through monitoring.
- Please explain any parts of the method to calculate that are not self-evident. Provide references as necessary. Explain implicit and explicit key assumptions in a transparent manner.
- When referring to and/or making use of life cycle analysis (LCAs) and/or LCA tools, methodology proponents provide, in a transparent manner, all equations, parameterizations and assumptions used in the LCA. For example, this could be accomplished by highlighting the relevant sections in an attached copy of the referenced LCA.
- The most recent IPCC default values may be used as necessary, when country or project specific data are not available or difficult to obtain.
- Methodologies requiring sampling as a part of monitoring clearly indicate the sampling method, statistical treatment of sampled data (e.g. confidence level, margin of error). A useful reference is the statistical treatment of sampled data for large scale CDM project activities in latest version of “Standard for Sampling And Surveys For CDM Project Activities and Programme of Activities” for large-scale CDM project activities.
- Emission reductions from reduced consumption of international transport fuels cannot be claimed under the JCM.

G. Calculation of project emissions

Project emissions are calculated on the basis of monitored electricity and fuel consumption.

$$PE_p = PEC_p * EF_{e,p} + \sum (PFC_{i,p} * NCV_{i,p} * EF_{CO_2,f,i,p})$$

- PE_p Project CO₂ emissions during the period p [tCO₂/p]
- PEC_p Project electricity consumption by applicable equipment during the period p [MWh/p]
- $EF_{e,p}$ CO₂ emissions factor of electricity during the period p [tCO₂/MWh]
- $PFC_{i,p}$ Project consumption of fossil fuel i of the applicable equipment during the period p [kl, t, 1000 Nm³/p]
- $NCV_{i,p}$ Net calorific value of fossil fuel i (diesel, kerosene, natural gas, etc.) during the period p [GJ/kl, t, 1000 Nm³]
*Any default value (XXGJ/kl, t, 1000 Nm³) or specific value for the project that the project developer measures is available.
- $EF_{CO_2,f,i,p}$ CO₂ emissions factor for fossil fuel i (diesel, kerosene, natural gas, etc.) during the period p [tCO₂/GJ]

- Where applicable, method to calculate project emissions should adhere to the instruction provided in the section on the reference emissions.

H. Calculation of emissions reductions

Emission reductions are calculated as the difference between the reference emissions and project emissions, as follows.

$$ER_p = RE_p - PE_p$$

- ER_p GHG emission reductions during the period p [tCO₂eq/p]
- RE_p Reference emissions during the period p [tCO₂eq/p]
- PE_p Project emissions during the period p [tCO₂eq/p]

- Please elaborate the method to calculate used to estimate, measure or calculate the emission reductions from the JCM project. In most cases, this will be simple equation with two terms: the reference emissions, and the project emissions.

I. Data and parameters fixed ex ante

The source of each data and parameter fixed ex ante is listed as below.

Parameter	Description of data	Source
EER_j	Percentage of improvement in energy consumption efficiency for building type j using BEMS	Results of feasibility studies and existing technical reports.
$EF_{e,p}$	CO ₂ emissions factor of electricity during the period p	IEA CO ₂ emissions from fuel combustion 2021 edition
$NCV_{i,p}$	Net calorific value of fossil fuel i (diesel, kerosene, natural gas, etc.) during the period p	IPCC guideline 2006 (2019 Refinement)
$EF_{CO_2,f,i,p}$	CO ₂ emissions factor of fossil fuel i (diesel, kerosene, natural gas, etc.) during the period p	IPCC guideline 2006 (2019 Refinement)

- Please identify sources of default values, where default values are applied to the proposed methodology.

6. Instructions for completing the Proposed Methodology Spreadsheet

Instructions for completing the Proposed Methodology Spreadsheet are provided below. The Input Sheet of the Proposed Methodology Spreadsheet should be completed as follows. A hypothetical Input Sheet of the Proposed Methodology Spreadsheet on building energy management systems (BEMS) is inserted to enhance the clarity of these Guidelines. This is purely indicative and does not imply that the Input Sheet of the Proposed Methodology Spreadsheet is adopted.

Proposed methodology spreadsheet (input sheet) [Attachment to Proposed Methodology Form]

Table 1: Parameters to be monitored *ex post*

(a) Monitoring point No.	(b) Parameters	(c) Description of data	(d) Estimated Values	(e) Units	(f) Monitoring option	(g) Source of data	(h) Measurement methods and procedures	(i) Monitoring frequency	(j) Other comments
(1)	$PFC_{D,p}$	Project diesel fuel consumption during the period p		kl/p	Option B	purchase records	- Collecting purchase amount from retailer invoices and inputting to a spreadsheet manually - Project deputy managers double check the input data with invoices every 6 months	once a month	
(2)	PEC_p	Project electricity consumption during the period p		MWh/p	Option C	monitored data	- Collecting electricity consumption data with validated/calibrated electricity monitoring devices and inputting to a spreadsheet electrically - Verified monitoring devices are installed and they are calibrated once a year. - Verification and calibration shall meet international standard on corresponding monitoring devices.	continuous	
(3)	$PFC_{L,p}$	Project LPG consumption during the period p		t/p	N/A	N/A	N/A	N/A	N/A
(4)	$PFC_{N,p}$	Project natural gas consumption during the period p		1000Nm ³ /p	N/A	N/A	N/A	N/A	N/A
(5)	$PFC_{K,p}$	Project kerosene consumption during the period p		kl/p	N/A	N/A	N/A	N/A	N/A

Table 2: Project-specific parameters to be fixed *ex ante*

(a) Parameters	(b) Description of data	(c) Estimated Values	(d) Units	(e) Source of data	(f) Other comments
EER_{Office}	Percentage of improvement in energy consumption efficiency for [Office Building] using BEMS		%	Past records of 30 similar size office buildings for the period of 2016-2020 measured by the project participant, BEMS provider. Data set of each building has the data of before and after BEMS implementation at least for one year respectively.	

Table3: *Ex-ante* estimation of CO₂ emission reductions

CO ₂ emission reductions	Units
0	tCO ₂ /p

[Monitoring option]

Option A	Based on public data which is measured by entities other than the project participants (Data used: publicly recognized data such as statistical data and specifications)
Option B	Based on the amount of transaction which is measured directly using measuring equipment (Data used: commercial evidence such as invoices)
Option C	Based on the actual measurement using measuring equipment (Data used: measured values)

The Calculation Process Sheet of the Proposed Methodology Spreadsheet should be completed as follows. A hypothetical Calculation Process Sheet of the Proposed Methodology Spreadsheet on building energy management systems (BEMS) is inserted to enhance the clarity of these Guidelines. This is purely indicative and does not imply that the Calculation Process Sheet is adopted.

Proposed methodology spreadsheet (Calculation Process Sheet) [Attachment to Proposed Methodology Form]				
1. Calculations for emission reductions	Fuel type	Value	Units	Parameter
Emission reductions during the period p		0	tCO ₂ /p	ER _p
2. Selected default values, etc.				
CO ₂ emission factor of electricity during the period p	Electricity	0.456	tCO ₂ /MWh	EF _{e,p}
Net calorific value of fossil fuel during the period p #1	Diesel	37.7	GJ/kl	NCV _{D,p}
CO ₂ emission factor of fossil fuel during the period p #1	Diesel	0.0687	tCO ₂ /GJ	EF _{CO₂,D,p}
Net calorific value of fossil fuel during the period p #2	LPG	50.8	GJ/t	NCV _{L,p}
CO ₂ emission factor of fossil fuel during the period p #2	LPG	0.0599	tCO ₂ /GJ	EF _{CO₂,L,p}
Net calorific value of fossil fuel during the period p #3	Natural gas	43.5	GJ/1000Nm ³	NCV _{N,p}
CO ₂ emission factor of fossil fuel during the period p #3	Natural gas	0.051	tCO ₂ /GJ	EF _{CO₂,N,p}
Net calorific value of fossil fuel during the period p #4	Kerosene	36.7	GJ/kl	NCV _{K,p}
CO ₂ emission factor of fossil fuel during the period p #4	Kerosene	0.0679	tCO ₂ /GJ	EF _{CO₂,K,p}
3. Calculations for reference emissions				
Reference emissions during the period p		0	tCO ₂ /p	RE _p
Project emissions during the period p		0	tCO ₂ /p	PE _p
Energy use reduction coefficient with BEMS	Office building	10.0	%	EER ₁
4. Calculations of the project emissions				
Project emissions during the period p		0	tCO ₂ /p	PE _p
Project emissions (electricity) during the period p		0	tCO _{2e} /p	
Project electricity consumption during the period p	Electricity	0	MWh/p	PEC _p
CO ₂ emission factor of electricity	Electricity	0.456	tCO ₂ /MWh	EF _{e,p}
Project emissions (diesel) during the period p		0	tCO ₂ /p	
Project diesel fuel consumption during the period p		0	kl/p	PFC _{D,p}
Net calorific value of fossil fuel	Diesel	37.7	GJ/kl	NCV _{D,p}
CO ₂ emission factor of fossil fuel	Diesel	0.0687	tCO ₂ /GJ	EF _{CO₂,D,p}
Project emissions (LPG) during the period p		0	tCO ₂ /p	
Project LPG consumption during the period p		0	t/p	PFC _{L,p}
Net calorific value of fossil fuel	LPG	50.8	GJ/t	NCV _{L,p}
CO ₂ emission factor of fossil fuel	LPG	0.0599	tCO ₂ /GJ	EF _{CO₂,L,p}
Project emissions (natural gas) during the period p		0	tCO ₂ /p	
Project natural gas consumption during the period p		0	1000Nm ³ /p	PFC _{N,p}
Net calorific value of fossil fuel	Natural gas	43.5	GJ/1000Nm ³	NCV _{N,p}
CO ₂ emission factor of fossil fuel	Natural gas	0.051	tCO ₂ /GJ	EF _{CO₂,N,p}
Project emissions (kerosene) during the period p		0	tCO ₂ /p	
Project kerosene consumption during the period p		0	kl/p	PFC _{K,p}
Net calorific value of fossil fuel	Kerosene	36.7	GJ/kl	NCV _{K,p}
CO ₂ emission factor of fossil fuel	Kerosene	0.0679	tCO ₂ /GJ	EF _{CO₂,K,p}

[List of Default Values]

Net calorific value of fossil fuel	NCV _{f,p}
Diesel	37.7 GJ/kl
LPG	50.8 GJ/t
Natural gas	43.5 GJ/1000Nm ³
Kerosene	36.7 GJ/kl

CO ₂ emission factor of fossil fuel	EF _{f,p}
Diesel	0.0687 tCO ₂ /GJ
LPG	0.0599 tCO ₂ /GJ
Natural gas	0.051 tCO ₂ /GJ
Kerosene	0.0679 tCO ₂ /GJ

Units of fossil fuel	
Diesel	kl/p
LPG	t/p
Natural gas	1000Nm ³ /p
Kerosene	kl/p

CO ₂ emission factor of electricity	EF _{e,p}
Electricity	0.456

Emissions reduction coefficient with BEMS	EER
Office building	10 %
Commercial building	20 %
Hotel	30 %
Hospital	40 %
Other	50 %

- The Input Sheet of the Proposed Methodology Spreadsheet consists of a table of parameters to be monitored ex post, and parameters to be fixed ex ante, which, combined, should provide a complete listing of the data that needs to be collected for the application of the methodology. The tables may include data that is collected from other sources (e.g. official statistics, expert judgment, proprietary data, IPCC Guidelines, commercial and scientific literature, etc.), measured, or sampled. Parameters that are calculated with equations provided in the methodology should not be included in this section.

For the “Parameters to be monitored ex post”(table 1), the following items are filled:

- *Parameter:* the variable used in equations in the proposed methodology;
 - *Description of data:* a clear and unambiguous description of the parameter;
 - *Estimated value:* this field is for the project participants to fill in to calculate emission reductions, and may be left blank in the proposed methodology.
 - *Unit:* The International System Unit (SI units – refer to < <https://www.bipm.org/en/measurement-units> >)
 - *Monitoring option:* please select option(s) from below. If appropriate, please provide the order of priority and the conditions when the options are chosen.
 - *Option A:* Based on public data which is measured by entities other than the project participants (Data used: publicly recognized data such as statistical data and specifications)
 - *Option B:* Based on the amount of transaction which is measured directly using measuring equipment (Data used: commercial evidence such as invoices)
 - *Option C:* Based on the actual measurement using measuring equipment (Data used: measured values)
 - *Source of data:* A description which data sources should be used to determine this parameter. Clearly indicate how the values are to be selected and justified, for example, by explaining:
 - *What types of sources are suitable* (official statistics, expert judgment, proprietary data, IPCC, commercial and scientific literature, etc.);
 - *What spatial level of data is suitable* (local, regional, national, international).
 - *Measurement methods and procedures:* For option B and C, a description of the measurement procedures or reference to appropriate standards. Provide also QA/QC procedures.
 - *Monitoring frequency:* A description of the frequency of monitoring (e.g. continuously, annually, etc.).
 - *Other Comments:* Other input not covered by the items above.
- *Where applicable, the table “Parameters to be fixed ex ante”(table 2), should also adhere to the instruction provided above. Data that is determined only once and remains fixed should be considered under “I. Data and parameters fixed ex ante”.*

Annex I. Sectoral Scopes for the JCM

1. Energy industries (renewable - / non-renewable sources);
2. Energy distribution;
3. Energy demand;
4. Manufacturing industries;
5. Chemical industry;
6. Construction;
7. Transport;
8. Mining/Mineral production;
9. Metal production;
10. Fugitive emissions from fuels (solid, oil and gas);
11. Fugitive emissions from production and consumption of halocarbons and sulphur hexafluoride;
12. Solvents use;
13. Waste handling and disposal;
14. Afforestation and reforestation;
15. Agriculture.

**Joint Crediting Mechanism Guidelines for Developing
Project Design Document and Monitoring Report**

CONTENTS

1. Scope and applicability	34
2. Terms and definitions	34
3. General guidelines.....	34
4. Developing a PDD	35
4.1. Completing a PDD form.....	35
4.2. Developing a Monitoring Plan.....	39
4.3. Preparing for actual measurement	40
5. Monitoring.....	43
5.1. Conducting monitoring.....	43
5.2. Data correction for actual measurement	43
5.3. Recording and archiving data	44
6. Developing a Monitoring Report	44
Appendix: Accuracy Level and Calibration	46

1. Scope and applicability

304. The “Joint Crediting Mechanism Guidelines for Developing Project Design Document and Monitoring Report” (hereinafter referred to as “these Guidelines”) are intended to assist project participants in developing Joint Crediting Mechanism (hereinafter referred to as “JCM”) project design document (hereinafter referred to as “PDD”) and monitoring report.
305. These Guidelines describe standards which are requirements to be met, except guidance indicated with terms “should” and “may” as defined in paragraph 310 below.

2. Terms and definitions

306. “Project design document (PDD)” is prepared by the project participant of a JCM project and sets out the JCM project in detail, in line with the JCM rules and guidelines.
307. “Monitoring” is collecting and archiving all relevant data necessary for estimating GHG emission that are significant and reasonably attributable to a registered JCM project.
308. “Monitoring plan” sets out the methodology to be used by project participants for the monitoring of, and by third-party entities for verification of the amount of GHG emission reductions achieved by the JCM project.
309. “Monitoring report” is prepared by a project participant and sets out the GHG emission reductions of an implemented registered JCM project for a particular monitoring period.
310. The following terms apply in these Guidelines:
- (a) “Should” is used to indicate that among several possibilities, one course of action is recommended as particularly suitable;
 - (b) “May” is used to indicate what is permitted.
311. Terms in these Guidelines are defined in “JCM Glossary of Terms” available on the JCM website.

3. General guidelines

312. When designing a proposed JCM project and developing a PDD and a monitoring report, project participants apply these Guidelines and the selected methodology(ies), which contain(s) approved methodology document(s) and Monitoring Spreadsheet(s).
313. The Monitoring Spreadsheet is provided as a part of each approved methodology and it consists of:
- (a) Monitoring Plan Sheet (input sheet and calculation process sheet) which is used before validation for developing a monitoring plan and calculating emission reductions *ex ante*;
 - (b) Monitoring Structure Sheet which is used before validation for developing an operational and management structure to be implemented in order to conduct monitoring;
 - (c) Monitoring Report Sheet (input sheet and calculation process sheet) which is used before verification for developing a monitoring report and calculating emission reductions *ex post*.
314. A PDD consists of a completed PDD form and monitoring plan using Monitoring Plan Sheet and Monitoring Structure Sheet. A monitoring report is completed by using Monitoring Report Sheet.
315. The project participants provide a description of the project that provides a comprehension of the nature of the project and its implementation.
316. The project participants monitor the registered JCM project and its emission reductions. The project participants establish and apply quality management procedures to manage data and information. The project participants should reduce, as far as is practical, uncertainties related to the quantification of emission reductions.
317. These Guidelines, the PDD form, and Monitoring Spreadsheet can be obtained electronically from the JCM website.
318. The Joint Committee may revise the PDD form and the Monitoring Spreadsheet if necessary.
319. The Monitoring Spreadsheet may be revised when the corresponding approved methodology is revised.
320. The PDD form and the Monitoring Spreadsheet are completed in English language.
321. The PDD form and the Monitoring Spreadsheet are not to be altered, that is, are to be completed without modifying its format, font, headings, except for those referred in paragraph 322 below.
322. Rows may be added to the table in the Annex of the PDD form.
323. Where a PDD contains information that the project participants wish to be treated as confidential or proprietary, the project participants are required to submit documentation in two versions:
- (a) One version where all parts containing confidential or proprietary information are made illegible (e.g. by covering those parts with black ink or overwrite those parts with letters such as “XXX”) so that the version can be made publicly available without displaying confidential or proprietary information;
 - (b) Another version containing all information that is to be treated as strictly confidential or proprietary by all parties handling this documentation (the third-party entities, the Joint Committee members, external experts).
324. Description related to application of the eligibility criteria and the environmental impact assessment is not considered confidential or proprietary.
325. The presentation of values in the PDD, including those used for the calculation of emission reductions, should be in international standard format e.g. 1,000 representing one thousand and 1.0 representing one. The units used should be accompanied by their equivalent S.I. units/norms (thousand/million) as part of the requirement to ensure transparency and clarity.

4. Developing a PDD

In the following section, a hypothetical project is described in red color as an example to show how to fill in the PDD form, Monitoring Plan Sheet, and Monitoring Structure Sheet.

4.1. Completing a PDD form

<Example of a completed PDD>

A. Project description

A.1. Title and reference number of the project idea note (PIN) of the JCM project

Title	Energy Management System application for office buildings in (Partner Country)
PIN reference number	XX_PIN000

Please indicate technology(ies) applied as well as sector that the project is implemented and the reference number of the PIN which was submitted to the Joint Committee and had no objection by the Joint Committee prior to the registration request.

A.2. General description of project and applied technologies and/or measures

The proposed JCM project aims to improve electricity and fossil fuel consumption by introducing Energy Management System in existing buildings in (Partner Country).

The key technology is to introduce optimum control and operation of buildings to achieve energy savings. Even without adopting facility investment measures such as replacement of existing facilities with more energy efficient ones, the optimum control and operation of building facilities can bring energy savings. Introducing Energy Management System will also lead to facility investment measures by analyzing facility energy consumptions.

The project covers 5 office buildings in "City X", (Partner Country). Energy Management System will be introduced in all buildings. LED, high-efficient air conditioning and fan inverter control will be introduced as part of the project in particular buildings.

The risk associated with the project may include malfunctioning of the project equipment, discontinuation of the project, omission of data, and intentional misstatement or noncompliance with laws and regulations which could prevent the achievement of the planned emission reductions. In order to avoid malfunctions, the project participants should identify risks that could substantially affect the project's GHG emission reductions and, if applicable, any measures to manage those risks.

Please include in the description:

- The purpose of the project;
- Explanation of how the proposed project reduces greenhouse gas emissions (i.e. what type of technology is being employed, what measures are conducted as part of the project, etc.).
- Identification of risks that could substantially affect the project's GHG emission reductions or removals.

A.3. Location of project, including coordinates

Country	(Partner Country)
Region/State/Province etc.:	N/A
City/Town/Community etc:	"City X"
Latitude, longitude	Building 1: N 10° 10' 00" and E 100° 10' 00" Building 2: N 10° 10' 10" and E 100°10' 10" Building 3: N 10° 10' 20" and E 100°10' 20" Building 4: N 10° 10' 30" and E 100° 10' 30" Building 5: N 10° 10' 40" and E 100°10' 40"

A.4. Name of project participants

(Partner Country)	ABC Buildings Holding Company Limited (Building 1, 2, 3) ABC Real Estate Company Limited (Building 4, 5)
Japan	Energy Management System Japan Ltd.

Please name all project participants from (Partner Country) and Japan in corresponding cell.

A.5. Duration

Starting date of project operation	01/04/2021
Expected operational lifetime of project	10 years
Type and duration of crediting period	Fixed crediting period (10 years) or Renewable crediting period (first, second or third crediting period) (5 years for each period)

Starting date of crediting period (input the information when requesting a renewal of crediting period)	DD/MM/YYYY
---	------------

Please provide starting date in DD/MM/YYYY and operational lifetime in years and months.
The starting date of a JCM project is the date on which the operation of a project begins.
Expected operational lifetime may be explained with publicly available statistical data, reference data from similar projects, legal durable years, expert judgment, etc.
Please select a type and duration of a crediting period from a fixed crediting period of 10 years or a renewable crediting period of five (5) years. When selecting a renewable crediting period, please indicate whether the crediting period is first, second or third.
The starting date of a crediting period is the date when the first monitoring period of the JCM project begins. When requesting a renewal of a crediting period, please indicate the starting date of the forthcoming crediting period which is the next date of the end of the previous crediting period.

A.6. Contribution from Japan

The state-of-the-art technology of building energy management system which has been developed by the Japanese project participant is introduced in the proposed project. The Japanese project participant transfers the technology through training to the (Partner Country) project participants. The Government of Japan provides financial support to the project.

Please include explanation of how Japan contributes to implementation of the project (i.e. finance, technology, training, support for O&M, etc).

B. Application of an approved methodology(ies)

B.1. Selection of methodology(ies)

Selected approved methodology No.	JCM XX AM001
Version number	Ver. 01.0
Selected approved methodology No.	N/A
Version number	N/A
Selected approved methodology No.	N/A
Version number	N/A

Please name approved methodology(ies) number and its version number applied to the proposed JCM project.

B.2. Explanation of how the project meets eligibility criteria of the approved methodology

Eligibility criteria	Descriptions specified in the methodology	Project information
Criterion 1	Energy Management System is introduced in already existing buildings.	All buildings covered in this project are already existing ones in City X.
Criterion 2	The operation and control of equipment and facilities to reduce energy consumption for indoor environments is carried out by Energy Management System itself, not just upgrading equipment for energy consumption.	Optimum control and operation of energy consuming facilities will be introduced in all buildings, which will achieve energy savings. This is the key technology of Energy Management System that has been developed and good performances in Japan.
Criterion 3	Be able to identify all energy consumption in the building(s) having equipment controlled by Energy Management System.	Energy Management System is used to monitor total energy consumptions in each building.
Criterion 4	N/A	N/A
Criterion 5	N/A	N/A
Criterion 6	N/A	N/A
Criterion 7	N/A	N/A
Criterion 8	N/A	N/A
Criterion 9	N/A	N/A
Criterion 10	N/A	N/A

Please copy all descriptions specified in the applied methodology for each criterion.
Then explain how the project meets each eligibility criterion with project detailed information.

C. Calculation of emission reductions

C.1. All emission sources and their associated greenhouse gases relevant to the JCM project

Reference emissions	
Emission sources	GHG type
Electricity consumption by lighting	CO ₂
Electricity consumption by air conditioner	CO ₂
Diesel fuel consumption by boiler	CO ₂
Electricity consumption by fan	CO ₂
Electricity consumption by ICT equipment	CO ₂
N/A	N/A
N/A	N/A
Project emissions	
Emission sources	GHG type
Electricity consumption by lighting	CO ₂
Electricity consumption by air conditioner	CO ₂
Diesel fuel consumption by boiler	CO ₂
Electricity consumption by fan	CO ₂
Electricity consumption by ICT equipment	CO ₂
N/A	N/A
N/A	N/A

Please list all emission sources and GHG types that are included in calculation of reference emissions and project emissions.

Please indicate in the description of "emission sources":

- Energy consumption facilities;
- Energy type;

For "GHG type" choose from CO₂, CH₄, N₂O, HFCs, PFCs, SF₆, and NF₃.

If the project involves more than one component, a separate table is to be provided in the Annex for each component or each approved methodology that is applied.

C.2. Figure of all emission sources and monitoring points relevant to the JCM project

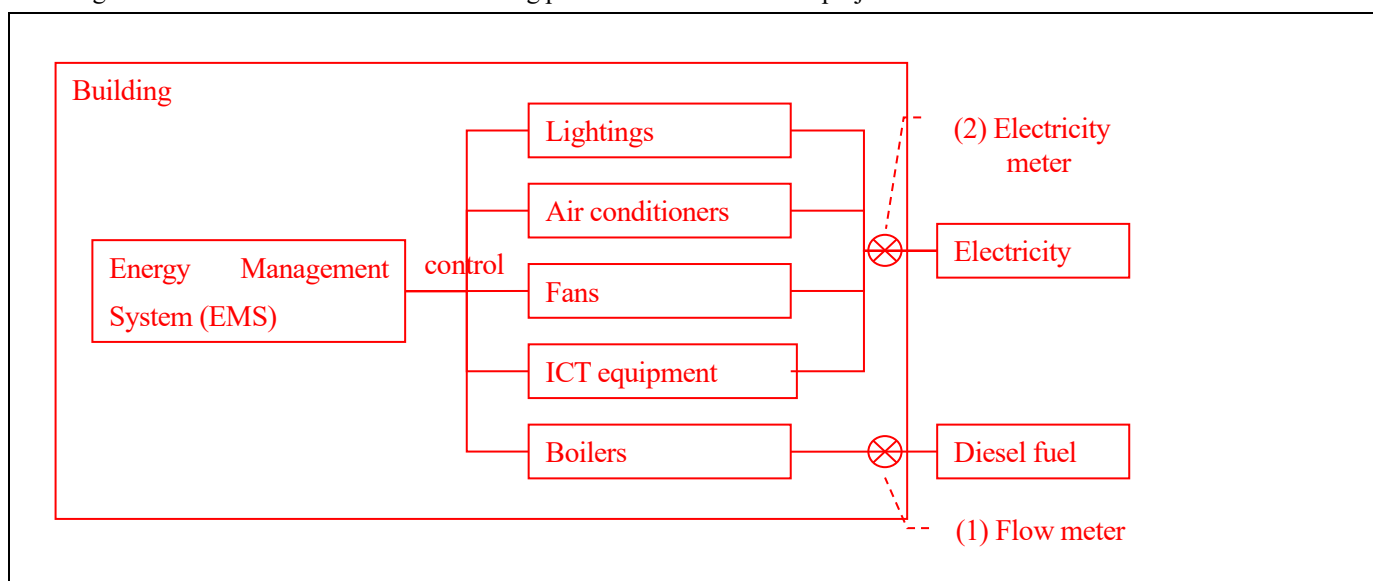

Please illustrate and describe all emission sources relevant to the project. Please also indicate all monitoring points for measurement* with types of equipment to be installed for the proposed project in the figure. Each monitoring point for measurement should be indicated with monitoring point number(s) corresponding to the number of parameters listed in the Monitoring Plan

“B”		energy saving measures has been distributed to all tenants in the project buildings.
Local authority	Such energy efficiency improvement measures comply with energy policies in <i>(Partner Country)</i> and are very much encouraged.	No action is needed.
N/A	N/A	N/A
N/A	N/A	N/A
N/A	N/A	N/A
N/A	N/A	N/A
N/A	N/A	N/A

Please identify stakeholders that have made comments and provide a summary of these comments.

Please explain how due account have been taken of comments received.

F. References

Energy Statistics 2020

Energy Conservation and Promotion Act

Reference lists to support descriptions in the PDD, if any.

Annex

Please provide separate tables for section C.1 and C.3 and further information related to other sections, if necessary.

Revision history of PDD

Version	Date	Contents revised
01.0	01/04/2021	First edition

4.2. Developing a Monitoring Plan

326. Project participants develop before validation of a monitoring plan using Monitoring Plan Sheet and Monitoring Structure Sheet in the corresponding Monitoring Spreadsheet of the methodology applied.
327. Project participants input estimated values for each parameter in the Monitoring Plan Sheet including those fixed ex ante for parameters not to be monitored.
328. Project participants also describe the following items for each parameter specified in the Monitoring Plan Sheet in line with the applied methodology(ies). Project participants may add detailed information specific to the proposed project to the contents given in the applied methodology.
- Estimated values: Provide the estimated values of the parameter for the purpose of calculating emission reductions *ex ante*;
 - Monitoring option: Select an option from below;
 - Option A: Based on public data which is measured by entities other than the project participants (Data used: publicly recognized data such as statistical data and specifications);
 - Option B: Based on the amount of transaction which is measured directly using measuring equipment (Data used: commercial evidence such as invoices);
 - Option C: Based on the actual measurement using measuring equipment (Data used: measured values).
 - Source of data: Provide the source of data used or to be used. Clearly indicate the type of data source (e.g. logbooks, daily records, surveys, etc.) and spatial level of data (e.g. local, regional, national, international), if applicable;
 - Measurement methods and procedures: Describe how the parameters are to be measured/calculated including Quality Assurance/Quality Control (hereinafter referred to as “QA/QC”) procedures applied. If the parameter will be measured, describe the equipment to be used to measure it, including details on accuracy level, and calibration information (frequency, date of calibration and validity) in line with section 4.3 below. Describe how the uncertainty affects the GHG emission reductions and how it has been addressed to minimize misrepresentation;
 - Monitoring frequency: Describe the monitoring frequency (e.g. continuously, annually).
329. The project participants ensure that data monitored and required for verification and issuance be kept and archived electronically for two years after the final issuance of credits.
330. In the Monitoring Structure Sheet, the project participants describe the operational and management structure to be implemented in order to conduct monitoring. The project participants establish and clearly indicate the roles and responsibilities of personnel, institutional arrangements, and procedures for data collection, archiving and reporting.
331. The project participants appoint a person who is responsible for overall monitoring activity including preparation of the monitoring report, and managing and archiving data. The responsible person for monitoring:

- (a) Ensures the quality of the monitoring report and the structure and procedure for producing such a document;
- (b) Appoints a person(s) responsible for managing monitoring points, when necessary, to collect data and maintain and control measuring instruments (including calibration/regular inspection) at monitoring points;
- (c) Ensures the assessment of the risks of malfunctioning of the project equipment, discontinuation of the project, omission of data, and intentional misstatement or noncompliance with laws and regulations which could prevent the achievement of the planned emission reductions or removals.

4.3. Preparing for actual measurement

- 332. For monitoring of parameters under Option C (i.e. parameters monitored through actual measurement), the project participants determine the frequency of calibration following the paragraphs 333, 334 and 335 below, unless otherwise stated in the applied methodology, and describe the frequency in the Monitoring Plan Sheet in line with paragraph 328(d).
- 333. The project participants confirm whether national laws and regulations on measurement exist for parameters under Option C.
- 334. Regarding parameters for which corresponding national laws and regulations on measurement exist, measuring equipment for those parameters is to be calibrated and/or qualified in accordance with the laws and regulations.
- 335. Regarding parameters for which national laws and regulations on measurement do not exist, measuring equipment is to be calibrated in line with international standards or manufacturers' specification.

<Example of a Monitoring Plan Sheet (Input Sheet)>

Monitoring Spreadsheet: JCM_XX_AM001_ver01.0

Monitoring Plan Sheet (input sheet) [Attachment to Project Design Document]

Table 1: Parameters to be monitored *ex post*

(a) Monitoring point No.	(b) Parameters	(c) Description of data	(d) Estimated Values	(e) Units	(f) Monitoring option	(g) Source of data	(h) Measurement methods and procedures	(i) Monitoring frequency	(j) Other comments
(1)	PFC _{D,p}	Project diesel fuel consumption during the period <i>p</i>	5,000	kl/p	Option B	purchase records	- Collecting purchase amount from retailer invoices and inputting to a spreadsheet manually - Project deputy managers double check the input data with invoices every 6 months	once a month	
(2)	PEC _p	Project electricity consumption during the period <i>p</i>	10,000	MWh/p	Option C	monitored data	- Collecting electricity consumption data with validated/calibrated electricity monitoring devices and inputting to a spreadsheet electrically - Verified monitoring devices are installed and they are calibrated once a year. - Verification and calibration shall meet international standard on corresponding monitoring devices.	continuous	
(3)	PFC _{L,p}	Project LPG consumption during the period <i>p</i>	0	t/p	N/A	N/A	N/A	N/A	N/A
(4)	PFC _{N,p}	Project natural gas consumption during the period <i>p</i>	0	1000Nm ³ /p	N/A	N/A	N/A	N/A	N/A
(5)	PFC _{K,p}	Project kerosene consumption during the period <i>p</i>	0	kl/p	N/A	N/A	N/A	N/A	N/A

Table 2: Project-specific parameters to be fixed *ex ante*

(a) Parameters	(b) Description of data	(c) Estimated Values	(d) Units	(e) Source of data	(f) Other comments
EER _{office}	Percentage of improvement in energy consumption efficiency for [Office Building] using BEMS	22	%	Past records of 30 similar size office buildings for the period of 2016-2020 measured by the project participant, BEMS provider. Data set of each building has the data of before and after BEMS implementation at least for one year respectively.	

Table3: *Ex-ante* estimation of CO₂ emission reductions

CO ₂ emission reductions	Units
1,945	tCO ₂ /p

[Monitoring option]

Option A	Based on public data which is measured by entities other than the project participants (Data used: publicly recognized data such as statistical data and specifications)
Option B	Based on the amount of transaction which is measured directly using measuring equipment (Data used: commercial evidence such as invoices)
Option C	Based on the actual measurement using measuring equipment (Data used: measured values)

<Example of a Monitoring Structure Sheet>

Monitoring Spreadsheet: JCM_XX_AM001_ver01.0

Monitoring Structure Sheet [Attachment to Project Design Document]

Responsible personnel	Role
Project Manager	Responsible for project planning, implementation, monitoring results and reporting.
Project Deputy Managers	Appointed to be in charge of approving the archived data after being checked and corrected when necessary.
Facility Managers	Appointed to be in charge of monitoring procedure (data collection and storage), including monitoring equipment and calibrations, and training of monitoring personnel.
Operators	Appointed to be in charge of checking the archived data for irregularity and lack.
N/A	N/A
N/A	N/A
N/A	N/A

5. Monitoring**5.1. Conducting monitoring**

336. Project participants conduct monitoring in line with the monitoring plan of the registered PDD.
- 5.2. Data correction for actual measurement
337. For monitoring of parameters under Option C (i.e. parameters monitored through actual measurement), the project participants calibrate measuring equipment as per the monitoring plan.
338. The project participants determine the necessity for data correction in calculation of emission reductions following the decision tree shown in Figure 1 below.
339. Regarding parameters for which corresponding national laws and regulations on measurement exist, the project participants:
- (a) Apply measured values (uncorrected values) to those parameters in calculation of emission reductions, if measuring equipment is calibrated and/or qualified in accordance with the national laws and regulations on measurement;
 - (b) Do not apply measured values in calculation of emission reductions for that monitoring period, if measuring equipment is not calibrated and/or qualified in accordance with the national laws and regulations on measurement.
340. Regarding parameters for which national laws and regulations on measurement do not exist, the project participants check whether the instrumental errors identified in the calibration test stay within the required level of accuracy (i.e. $\pm 5\%$).
341. For parameters described in paragraph 340, if measuring equipment is calibrated in line with the monitoring plan, the project participants:
- (a) Apply measured values (uncorrected values) to those parameters in calculation of emission reductions, where the instrumental errors of the measuring equipment stay within $\pm 5\%$;
 - (b) Correct measured values by applying the difference resulted from the instrumental error and required level of accuracy to the measured values during the period between the date of the previous calibration and the concerned calibration, in line with the Appendix to these Guidelines, and apply the corrected values to those parameters in calculation of emission reductions, where the instrumental errors of the measuring equipment do not stay within $\pm 5\%$.
342. For parameters described in paragraph 340, if measuring equipment is not calibrated in line with the monitoring plan, but calibration is implemented after the scheduled date, the project participants:
- (a) Apply measured values (uncorrected values) to those parameters in calculation of emission reductions, where the instrumental errors identified in the delayed calibration test stay within $\pm 5\%$;
 - (b) Correct measured values by applying the difference resulted from the instrumental error identified in the delayed calibration and required level of accuracy to the measured values during the period between the date of previous calibration and the actual date of calibration in line with the Appendix to these Guidelines, and apply the corrected values to those parameters in calculation of emission reductions, where the instrumental errors identified in the delayed calibration test do not stay within $\pm 5\%$.
343. Correction of values in line with paragraph 341(b) and 342(b) are conducted in a manner which results in a conservative calculation of emission reductions, as shown in the Appendix.
344. For parameters described in paragraph 340, if measuring equipment is not calibrated in line with the monitoring plan and calibration is not implemented after the scheduled date, the project participants do not apply measured values in calculation of emission reductions for that monitoring period.

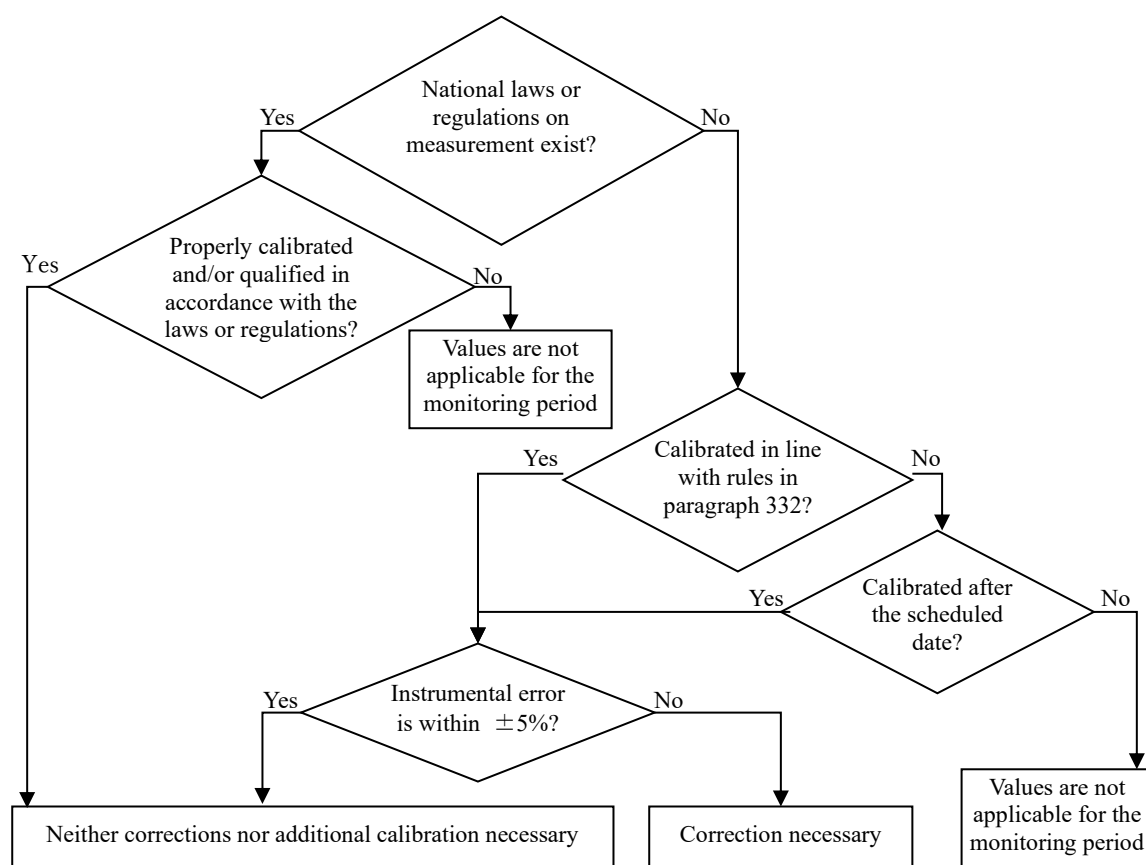

Figure 1 Decision tree for data correction

5.3. Recording and archiving data

345. The project participants record and archive the data as per the monitoring plan.

346. When conducting monitoring, the project participants archive the evidence and records that validate the figures to be stated in the monitoring report(s). It includes the source documents that form the basis for calculations and other information underlying the emission reductions.

6. Developing a Monitoring Report

347. The project participants develop a monitoring report using the Monitoring Report Sheet applied to the registered JCM project.

348. For each parameter in the Monitoring Report Sheet, the project participants describe appropriate information corresponding to the following items:

- (a) Monitoring period: Describe the monitoring period;
- (b) Monitored values: Provide the values of the monitored parameter for the purpose of calculating emission reductions;
- (c) Monitoring option: Fill in the monitoring option used;
- (d) Source of data: Provide the source of data used. Clearly indicate the type of data source (e.g. logbooks, daily records, surveys, etc.) and spatial level of data (e.g. local, regional, national, international), if applicable;
- (e) Measurement methods and procedures: Describe how the parameters are measured/calculated including QA/QC procedures applied. If the parameter is measured, describe the equipment used to measure it, including details on accuracy level, and calibration information (frequency, date of calibration and validity);
- (f) Monitoring frequency: Describe the monitoring frequency.

<Example of a Monitoring Report Sheet>

Monitoring Spreadsheet: JCM_XX_AM001_ver01.0

Monitoring Report Sheet (input sheet) [For Verification]

Table 1: Parameters monitored ex post

(a) Monitoring period	(b) Monitoring point No.	(c) Parameters	(d) Description of data	(e) Monitored Values	(f) Units	(g) Monitoring option	(h) Source of data	(i) Measurement methods and procedures	(j) Monitoring frequency	(k) Other comments
//2021-//2022	(1)	PFC _{D,p}	Project diesel fuel consumption during the period <i>p</i>	4,000	kl/p	Option B	purchase records	- Collecting purchase amount from retailer invoices and inputting to a spreadsheet manually - Project deputy managers have double checked the input data with invoices on ***//2021 and ***//2022. - An input error was found on the data of ***//2021, then corrective action was instructed to a facility manager.	once a month	
//2021-//2022	(2)	PEC _p	Project electricity consumption during the period <i>p</i>	8,000	MWh/p	Option C	monitored data	- Collecting electricity consumption data with verified/calibrated electricity monitoring devices and inputting to a spreadsheet electrically - Three verified monitoring devices fully compliant with the international standard ISOXX are installed on ***//2021. - Electricity meter was calibrated on ***//2021 and its accuracy (1.5%) was confirmed to be valid until ***//2022.	continuous	
N/A	N/A	PFC _{L,p}	Project LPG consumption during the period <i>p</i>	0	t/p	N/A	N/A	N/A	N/A	N/A
N/A	N/A	PFC _{N,p}	Project natural gas consumption during the period <i>p</i>	0	1000Nm ³ /p	N/A	N/A	N/A	N/A	N/A
N/A	N/A	PFC _{K,p}	Project kerosene consumption during the period <i>p</i>	0	kl/p	N/A	N/A	N/A	N/A	N/A

Table 2: Project-specific parameters fixed ex ante

(a) Parameters	(b) Description of data	(c) Estimated Values	(d) Units	(e) Source of data	(f) Other comments
EER _{office}	Percentage of improvement in energy consumption efficiency for [Office Building] using BEMS	22	%	Past records of 30 similar size office buildings for the period of 2016-2020 measured by the project participant, BEMS provider. Data set of each building has the data of before and after BEMS implementation at least for one year respectively.	

Table 3: Ex-post calculation of CO₂ emission reductions

Monitoring Period	CO ₂ emission reductions	Units
//2021-//2022	1,556	tCO ₂ /p

[Monitoring option]

Option A	Based on public data which is measured by entities other than the project participants (Data used: publicly recognized data such as statistical data and specifications)
Option B	Based on the amount of transaction which is measured directly using measuring equipment (Data used: commercial evidence such as invoices)
Option C	Based on the actual measurement using measuring equipment (Data used: measured values)

Appendix: Accuracy Level and Calibration

349. The following provides an illustrative example for applying the matters in paragraphs 341 and 342 on the treatment of monitored parameters for which national laws and regulations on measurement do not exist.
350. A hypothetical biomass power generation project is envisaged. The project generates electricity from biomass fuel and supplies it to the grid system. The project consumes diesel oil for a start-up and auxiliary fuel source to meet the required level of output. In this example, emission reductions are calculated as the difference between reference emissions calculated by multiplying electricity generated and emission factor of the grid, and project emissions calculated by multiplying diesel oil consumed and its emission factor.
351. If the instrumental errors identified in the calibration test do not exceed $\pm 5\%$, then no correction is needed. An example is shown in example 1.
352. If the instrumental errors identified in the calibration test exceeds $\pm 5\%$, then a correction to the measured values is applied. The degree of correction is the identified errors minus 5%, in a way that results in a conservative calculation of emission reductions. An example is shown in example 2.

Example 1: When the instrumental errors identified in the calibration test do not exceed $\pm 5\%$

Measured value	Parameter	Error identified during (delayed) calibration	Applied values
100 MWh	Electricity supplied to the grid (required parameter for calculating reference emissions)	$\pm 0.2\%$	100MWh (uncorrected), since the error identified by calibration is less than or equal to the required accuracy level of $\pm 5\%$, no correction needed
800 liters of diesel	Diesel flow to the power plant (required parameter for calculating project emissions)	$\pm 2\%$	800 liters (uncorrected), since the error identified by calibration is less than or equal to the required accuracy level of $\pm 5\%$, no correction needed

Example 2: When the instrumental errors identified in the calibration test exceeds $\pm 5\%$

Measured value	Parameter	Error identified during (delayed) calibration	Applied values
100 MWh	Electricity supplied to the grid (required parameter for calculating reference emissions)	$\pm 7\%$	$100\text{MWh} \times (1 - (7\% - 5\%)) = 98\text{MWh}$, since the error identified by calibration is more than the required accuracy level of $\pm 5\%$, and it is conservative to take the lower end of the corrected value.
800 liters of diesel	Diesel flow to the power plant (required parameter for calculating project emissions)	$\pm 10\%$	$800\text{ liters} \times (1 + (10\% - 5\%)) = 840\text{ liters}$, since the error identified by calibration is more than the required accuracy level of $\pm 5\%$, and it is conservative to take the higher end of the corrected value.

**Joint Crediting Mechanism Guidelines for Developing
Sustainable Development Implementation Plan and Report**

CONTENTS

1. Objectives.....	48
2. Scope and applicability	48
3. Terms and definitions	48
4. General guidelines.....	48
5. Developing an SDIP and an SDIR	48
5.1. Completing an SDIP form	48
5.2. Completing an SDIR form.....	52

1. Objectives

353. The Joint Crediting Mechanism (hereinafter referred to as “JCM”) aims to contribute to the sustainable development in (Partner Country) through the implementation of JCM projects, and the “Joint Crediting Mechanism Guidelines for Developing Sustainable Development Implementation Plan and Report” (hereinafter referred to as “these Guidelines”) facilitates this objective.

2. Scope and applicability

354. These Guidelines are applicable to project participants, the Joint Committee and the secretariat with respect to evaluation of the contribution of JCM projects to the sustainable development in (*Partner Country*).

355. These guidelines are intended to assist project participants in developing JCM sustainable development implementation plan (hereinafter referred to as “SDIP”) and sustainable development implementation report (hereinafter referred to as “SDIR”).

356. These Guidelines describe standards which are requirements to be met, except guidance indicated with terms “should” and “may” as defined in paragraph 359 below.

3. Terms and definitions

357. “SDIP” is prepared by the project participant of a JCM project by filling in “JCM Sustainable Development Implementation Plan Form” (hereinafter referred to as “SDIP form”) and sets out in detail, in line with the JCM rules and guidelines, a plan of the JCM project to contribute to sustainable development.

358. “SDIR” is prepared by the project participant of a JCM project by filling in “JCM Sustainable Development Implementation Report Form” (hereinafter referred to as “SDIR form”) and sets out the result of SDIP implementation for a particular monitoring period.

359. The following terms apply in these Guidelines:

- (a) “Should” is used to indicate that among several possibilities, one course of action is recommended as particularly suitable;
- (b) “May” is used to indicate what is permitted.

360. Terms in these Guidelines are defined in “JCM Glossary of Terms” available on the JCM website.

4. General guidelines

361. When designing a proposed JCM project and developing an SDIP and an SDIR, project participants apply these Guidelines.

362. The project participants provide a comprehensive description of plan for contributions to sustainable development (hereinafter referred to as “SD”) through the proposed JCM project.

363. The project participants should conduct ex-ante analysis of the contribution to SD using the SDIP form and ex-post evaluation of the contribution to SD using the SDIR form.

364. These Guidelines, the SDIP form and the SDIR form can be obtained electronically from the JCM website.

365. The Joint Committee may revise the SDIP form and the SDIR form, if necessary.

366. The SDIP form and the SDIR form are completed in English language.

367. The presentation of values in the SDIP form or SDIR form, including those used for the calculation, where necessary, should be in international standard format e.g. 1,000 representing one thousand and 1.0 representing one. The units used should be accompanied by their equivalent S.I. units/norms (thousand/million) as part of the requirement to ensure transparency and clarity.

368. The SDIP form and the SDIR form are to be completed without its format, font and headings being altered.

369. Project participants are encouraged to refer to, as appropriate, the related local and/or national regulations and guidelines in their preparation of SDIP and SDIR.

5. Developing an SDIP and an SDIR

In the following section, a hypothetical project is described in red color as an example to show how to fill in the SDIP form and SDIR form.

5.1. Completing an SDIP form

<Example of a completed SDIP form>

A. Project description

A.1. Title of the JCM project

Energy Management System application for office buildings in (*Partner Country*)

A.2. Contact information

Name of the focal point entity(ies):	Global Buildings Holding Company Limited (Building 1, 2, 3)
Name of authorized signatory	
Last name:	First name:
Title:	

Please name the focal point entity of the proposed project.

B. Possible Contribution to Sustainable Development

B.1 Plan for possible contribution to SD

No.	Items	Questions	Yes/No	If the selected answer is “Yes” in the left-hand column, please describe the action plans in a blank cell in this column.
1	EIA	Does the proposed project require official/legal process of EIA?	No <input checked="" type="checkbox"/>	
			Yes <input type="checkbox"/>	
2		Does the proposed project emit air pollutants?	No <input checked="" type="checkbox"/>	
			Yes <input type="checkbox"/>	
3		Does the proposed project discharge water pollutants or substances which influence BOD, COD or pH, etc.?	No <input checked="" type="checkbox"/>	
			Yes <input type="checkbox"/>	
4	Pollution Control (No answer is necessary if EIA is required)	Does the proposed project generate waste?	No <input type="checkbox"/>	
			Yes <input checked="" type="checkbox"/>	A small amount of waste is expected during the set-up of equipment. However, generated waste will be treated in line with the company recycling plan for proper disposal.
5		Does the proposed project increase noise, vibration and/or odor beyond the levels required by laws or regulations?	No <input type="checkbox"/>	
			Yes <input checked="" type="checkbox"/>	Certain noise increase is expected. However, proper noise control measures will be carried out.
6		Does the proposed project cause ground subsidence?	No <input checked="" type="checkbox"/>	
			Yes <input type="checkbox"/>	
7	Safety and Health	Does the proposed project pose a dangerous condition for local communities as well as individuals involved in the project, during either its construction or its operation?	No <input type="checkbox"/>	
			Yes <input checked="" type="checkbox"/>	The project may create a dangerous condition during its installation. However, preventative measures will be carried out for securing safety of workers during its installation.
8		Is the proposed project site located in protected areas designated by national laws or international treaties and conventions?	No <input checked="" type="checkbox"/>	
			Yes <input type="checkbox"/>	
9	Natural Environment and Biodiversity	Does the proposed project change land use of the community and protected habitats for endangered species designated by national laws or international treaties and conventions?	No <input checked="" type="checkbox"/>	
			Yes <input type="checkbox"/>	
10		Does the proposed project introduce foreign species?	No <input checked="" type="checkbox"/>	
			Yes <input type="checkbox"/>	

11		Does the proposed project involve construction activities considered to affect natural environment and biodiversity (e.g., noise, vibrations, turbid water, dust, exhaust gases, and wastes)?	No <input checked="" type="checkbox"/>	
			Yes <input type="checkbox"/>	
12		Does the proposed project use surface water, ground water and/or deep ground water?	No <input checked="" type="checkbox"/>	
			Yes <input type="checkbox"/>	
13	Economy	Does the proposed project have negative impact on local workforce capacity?	No <input checked="" type="checkbox"/>	
			Yes <input type="checkbox"/>	
14	Economy	Does the proposed project have negative impact on local community's welfare?	No <input checked="" type="checkbox"/>	
			Yes <input type="checkbox"/>	
15	Social and Local Community Participation	Please describe what best possible measures the project participants of the proposed project take to ensure human rights through the supply chain and the implementation of the proposed project, and demonstrate that there is no violation of human rights.	-	
16		Please describe, if possible, how the project participants of the proposed project respect, promote and consider their respective right to health, the rights of indigenous peoples, local communities, migrants, children, persons with disabilities and people in vulnerable situations and the right to development, as well as gender equality, empowerment of women and intergenerational equity.	-	
17		Does the proposed project cause any resettlement or other types of conflict?	No <input checked="" type="checkbox"/>	
			Yes <input type="checkbox"/>	
18		Does the proposed project include activities to respond to, and follow up, comments and complaints that have been received from local communities, particularly from the public consultation?	No <input checked="" type="checkbox"/>	
		Yes <input type="checkbox"/>		
19		Do the project participants fail to comply with any laws and/or ordinances associated with the	No <input checked="" type="checkbox"/>	

		working conditions of local communities which the project participants should observe in the project?	Yes <input type="checkbox"/>	
20	Technology	Does the proposed project fail to include activities to build capacity of human resources through technology transfer and technical assistance?	No <input checked="" type="checkbox"/>	
			Yes <input type="checkbox"/>	

Where applicable, please identify the impact of a proposed project on its surroundings using the guiding questions. If the selected answer is “Yes” describe in a blank cell in the rightmost column above a plan for contribution to sustainable development while ensuring compliance with national and local regulations. Please answer each question and select Yes or No (including “Not sure at the stage of submitting SDIP”) depending on the situation at the stage of submitting SDIP.

References
[Law No. 19,300 \(The Environment Law\)](#)

List the references used to support descriptions provided, if any.

5.2. Completing an SDIR form

<Example of a completed SDIR form>

A. Project description

A.1. Title of the JCM project

Energy Management System application for office buildings in *(Partner Country)*

A.2. General information of project

Reference Number	XX00X
Registration date	dd/mm/yyyy
Monitoring period	Start: dd/mm/yyyy, End: dd/mm/yyyy

B. Contribution to Sustainable Development

B.1 Check list for contribution to SD

No.	Items		Not identified	Identified	If "Identified" is checked in the box, please describe the corrective actions
1	EIA	Project is included in the EIA reporting to the Government of (<i>Partner Country</i>)	<input checked="" type="checkbox"/>	<input type="checkbox"/>	
2	Pollution Control	Occurrence of pollution in ambient air quality	<input checked="" type="checkbox"/>	<input type="checkbox"/>	
3		Occurrence of pollution in water quality	<input checked="" type="checkbox"/>	<input type="checkbox"/>	
4		Occurrence of waste generation	<input checked="" type="checkbox"/>	<input type="checkbox"/>	
5		Occurrence of noise and/or vibration	<input checked="" type="checkbox"/>	<input type="checkbox"/>	
6		Occurrence of ground subsidence	<input checked="" type="checkbox"/>	<input type="checkbox"/>	
7		Occurrence of ambient odor	<input checked="" type="checkbox"/>	<input type="checkbox"/>	
8	Safety and Health	Occurrence of accident or occupational accident	<input type="checkbox"/>	<input checked="" type="checkbox"/>	An accident occurred. But its damage was compensated, and the safety measures were revised for local communities as well as individuals involved in the project.
9	Natural Environment and Biodiversity	Change of protected area condition	<input checked="" type="checkbox"/>	<input type="checkbox"/>	
10		Change of land use change and ecosystem condition	<input checked="" type="checkbox"/>	<input type="checkbox"/>	
11		Introduction of foreign species	<input checked="" type="checkbox"/>	<input type="checkbox"/>	
12		Environmental impact during construction	<input checked="" type="checkbox"/>	<input type="checkbox"/>	
13		Use of surface water, ground water and/or deep ground water	<input checked="" type="checkbox"/>	<input type="checkbox"/>	
14	Economy	Decrease in local workforce capacity	<input checked="" type="checkbox"/>	<input type="checkbox"/>	
15		Declination of local community welfare	<input checked="" type="checkbox"/>	<input type="checkbox"/>	
16	Social and Local Community Participation	Violation of human rights through the supply chain and implementation of the project	<input checked="" type="checkbox"/>	<input type="checkbox"/>	
17		Problems related to the right to health, the rights of indigenous peoples, local communities, migrants, children, persons with disabilities and people in vulnerable situations and the right to development, as well as gender equality, empowerment of women and intergenerational equity	<input checked="" type="checkbox"/>	<input type="checkbox"/>	
18		Occurrence of resettlement or conflict	<input checked="" type="checkbox"/>	<input type="checkbox"/>	
19		Failure to follow up comments and complaints successfully	<input checked="" type="checkbox"/>	<input type="checkbox"/>	
20		Violation of regulatory working condition	<input checked="" type="checkbox"/>	<input type="checkbox"/>	
21	Technology	Failure to build human and institutional capacity by technology transfer	<input checked="" type="checkbox"/>	<input type="checkbox"/>	

Please check each box, either in "Not Identified" or "Identified" depending on the kind of impact through the implementation of the project in line with each identified item. Where "Identified" box is checked, project participants are requested to describe the corrective actions on each "Identified" impact.

B.2 Please describe the contribution of the JCM project to the sustainable development in (Partner Country) below:



Joint Crediting Mechanism Guidelines for Designation as a Third-Party Entity

CONTENTS

1. Objectives.....	56
2. Scope and applicability	56
3. Normative references	56
4. Terms and definitions	56
5. Designation as a TPE	56
5.1. Requirements for designation as a TPE	56
5.2. Procedures for designation as a TPE.....	56
6. Suspension, withdrawal and reinstatement of the designation	57
6.1. Conditions for suspension or withdrawal	57
6.2. Procedures for suspension or withdrawal	57
6.3. Procedures following suspension or withdrawal	58
6.4. Procedures for reinstatement of designation	58
Annex 1: Sectoral Scopes for the JCM	58
Annex 2: Application form for designation as a TPE.....	59

1. Objectives

370. The objectives of the “Joint Crediting Mechanism Guidelines for designation as a Third-Party Entity” (hereinafter referred to as “these Guidelines”) are as follows:
- (a) To establish the criteria and procedures for designation of third-party entities (hereinafter referred to as the “TPEs”), to perform validation and verification activities under the Joint Crediting Mechanism (hereinafter referred to as “JCM”); and
 - (b) To establish the criteria and procedures for suspension and withdrawal, and procedures for reinstatement of designation of TPEs.

2. Scope and applicability

371. These Guidelines are applicable to candidate entities, TPEs, the Joint Committee and the secretariat with respect to designation, suspension and withdrawal of TPEs.
372. These Guidelines describe standards which are requirements to be met, except guidance indicated with terms “should” and “may” as defined in paragraph 376 below.

3. Normative references

373. The following referenced documents are indispensable for the application of these Guidelines:
- (a) ISO 14065:2020 General principles and requirements for bodies validating and verifying environmental information
 - (b) Clean Development Mechanism Accreditation Standard for Operational Entities; and
 - (c) Article 6.4 Accreditation Standard.

4. Terms and definitions

374. TPEs are entities designated by the Joint Committee as qualified to validate proposed JCM projects and/or verify GHG emission reductions or removals as a result of registered JCM projects.
375. Candidate entities are entities which have applied to be designated by the Joint Committee as TPEs.
376. The following terms apply in these Guidelines:
- (a) “Should” is used to indicate that among several possibilities, one course of action is recommended as particularly suitable; and
 - (b) “May” is used to indicate what is permitted.
377. Terms in these Guidelines are defined in JCM Glossary of Terms available on the JCM website.

5. Designation as a TPE

- 5.1. Requirements for designation as a TPE
378. To be designated as a TPE, a candidate entity fulfills all requirements as listed paragraphs 379 and 380 below.
379. Candidate entities are either:
- (a) Entities accredited under ISO 14065 by an accreditation body that is a member of the International Accreditation Forum (hereinafter referred to as “IAF”) based on ISO 14064-2; or
 - (b) Designated Operational Entities (hereinafter referred to as “DOEs”) or operational entities accredited by the Executive Board under the Clean Development Mechanism (hereinafter referred to as “CDM”) and/or DOEs accredited by the Supervisory Body of the Article 6.4 mechanism.
380. Candidate entities have sufficient knowledge of the JCM between (*Partner Country*) and Japan by reading and knowing all applicable rules and guidelines of the JCM.
- 5.2. Procedures for designation as a TPE
381. Sectoral scopes under the JCM are described in Annex 1.
382. A candidate entity submits the application form as shown in Annex 2 in these Guidelines to the Joint Committee through the secretariat.
383. When a TPE wishes to be designated under the JCM for additional sectoral scopes, the TPE submits the application form and seeks its designation for those sectoral scopes.
384. The secretariat checks whether the application form is complete, and communicates the result to the candidate entity within seven (7) days after the receipt of the submission.
385. When the application is deemed complete, the Joint Committee decides whether to designate the candidate entity as a TPE or reject the application.
386. When the Joint Committee designates the candidate entity, applicable sectoral scopes under the JCM for such entity are decided on the basis of:
- (a) In case the candidate entities are accredited under ISO 14065, sectoral competence of the candidate entities as described in their application; and
 - (b) In case the candidate entities are designated/accredited under the CDM and/or the Article 6.4 mechanism, the sectoral scopes identical to those under the CDM and/or the Article 6.4 mechanism unless otherwise decided by the Joint Committee.
387. The secretariat notifies the result of the above decision to the candidate entity and makes the relevant information of the designated

TPE and the sectoral scopes publicly available through the JCM website.

388. When the TPE changes its contact details, the TPE notifies the secretariat of such changes by electronic means immediately.

6. Suspension, withdrawal and reinstatement of the designation³

6.1. Conditions for suspension or withdrawal of designation

389. The designation is suspended or withdrawn under the following conditions:

- (a) When the Joint Committee decides that the TPE no longer complies with the applicable JCM rules and guidelines following the review conducted by the Joint Committee;
- (b) When the status of the TPE changes regarding accreditation under ISO 14065 and/or accreditation/designation under the CDM and/or the Article 6.4 mechanism; and
- (c) When the TPE voluntarily withdraws its designation status under the JCM.

6.2. Procedures for suspension or withdrawal

6.2.1. Procedures for suspension or withdrawal following a review

390. The Joint Committee may conduct a review on whether a TPE continues to comply with the applicable JCM rules and guidelines. Such review may include on-site visits to evaluate the performance of a TPE. The Joint Committee may decide to appoint external experts or organizations which assist part of its work regarding the review.

391. If the Joint Committee has carried out a review and found that the TPE no longer complies with the applicable JCM rules and guidelines, the Joint Committee decides on whether to suspend or withdraw the designation of the TPE for some or all sectoral scopes, but only after the TPE has had the possibility of a hearing. The suspension or withdrawal immediately commences on the date when the decision is taken by the Joint Committee.

6.2.2. Procedures for suspension or withdrawal due to changes in the status of the TPE regarding accreditation under ISO 14065 and/or accreditation/designation under the CDM and/or the Article 6.4 mechanism

392. For a TPE accredited only under ISO 14065, when its accreditation under ISO 14065 is suspended or withdrawn for some or all sectoral scopes⁴, the designation of the TPE for the corresponding sectoral scopes under the JCM is suspended or withdrawn on the date such suspension or withdrawal commences.

393. For a TPE designated only under the CDM and/or the Article 6.4 mechanism, when the accreditation/designation is suspended or withdrawn for some or all sectoral scopes, the designation of the TPE for the corresponding sectoral scopes under the JCM is suspended or withdrawn on the date such suspension or withdrawal commences.

394. For a TPE accredited under ISO14065 and designated under the CDM and/or the Article 6.4 mechanism:

- (a) When any of accreditation under ISO 14065 or accreditation/designation under the CDM and/or the Article 6.4 mechanism is suspended or withdrawn for some or all sectoral scopes, the designation of the TPE for the corresponding sectoral scopes under the JCM is suspended or withdrawn on the date such suspension or withdrawal commences except for the cases described in subparagraphs (b) and (c) below;
- (b) When the TPE voluntarily withdraws the accreditation for some or all sectoral scopes under ISO 14065 or the TPE voluntarily withdraws the accreditation for some or all sectoral scopes under the CDM and/or the Article 6.4 mechanism, without being suspended, the designation of the TPE under the JCM is maintained for the corresponding sectoral scopes for which the TPE continues its accreditation or designation under the other programme(s); and
- (c) When the TPE voluntarily withdraws the accreditation for some or all sectoral scopes under ISO 14065 or the TPE voluntarily withdraws the accreditation for some or all sectoral scopes under the CDM and/or the Article 6.4 mechanism, which is currently under suspension, the designation of the TPE for the corresponding sectoral scopes under the JCM is suspended until the Joint Committee decides whether to withdraw or reinstate the designation.

395. In case the status of the TPE falls under the conditions described in paragraphs 392 to 394 above, the TPE notifies the Joint Committee of such status without delay.

6.2.3. Procedures for voluntary withdrawal by a TPE

396. A TPE may withdraw its designation status for some or all sectoral scopes by submitting the letter through electric means specified on the JCM website, to the Joint Committee indicating the following:

- (a) Name of the TPE with the signature of its authorized representative;
- (b) Sectoral scopes that the TPE wishes to withdraw; and
- (c) Date when the TPE wishes to withdraw its designation.

397. Voluntary withdrawal of the designation by a TPE for some or all sectoral scopes is effective on the same date indicated in line with paragraph 396(c) above.

398. Voluntary withdrawal of the designation by a TPE does not free the TPE from its contractual arrangement.

³ Suspension or withdrawal of the designation may be for some or all sectoral scopes.

⁴ "Withdrawal for some sectoral scopes" is described as "reducing scopes" under ISO 14065.

- 6.3. Procedures following suspension or withdrawal
399. When the designation of a TPE is suspended or withdrawn for some or all sectoral scopes, the Joint Committee makes the name of the TPE, its status regarding sectoral scopes suspended or withdrawn and the reasons for the suspension or withdrawal publicly available through the JCM website without delay.
400. When the designation of a TPE is suspended or withdrawn for some or all sectoral scopes, the TPE notifies all affected organizations including project participants which the TPE is under contract to perform JCM validation and/or verification activities by the time of suspension or withdrawal.
401. When the designation of a TPE is suspended, the TPE may continue its ongoing JCM validation and/or verification activities for which the contract was in force at the time of its suspension.
402. When the designation of a TPE is withdrawn for some or all sectoral scopes, the TPE does not continue any JCM validation and/or verification activities for the sectoral scopes withdrawn.
403. Projects which had been already validated or verified by the TPE are not affected by its suspension or withdrawal, however, the Joint Committee may conduct any actions to these projects.
- 6.4. Procedures for reinstatement of designation
404. When a TPE whose designation is suspended or withdrawn for some or all sectoral scopes in line with paragraph 389(a) above wishes its designation to be reinstated, the TPE submits the application form and documents which explain corrective actions for the causes of its suspension.
405. When a TPE whose designation is suspended or withdrawn for some or all sectoral scopes in line with paragraph 389(b) above wishes its designation to be reinstated after the suspension is lifted or the accreditation is reinstated under ISO 14065 the CDM and/or the Article 6.4 mechanism, the TPE submits the application form.
406. When a TPE whose designation is voluntarily withdrawn in line with paragraph 389(c) above wishes its designation to be reinstated, the entity submits the application form.
407. The Joint Committee decides on whether to reinstate the designation of the suspended or withdrawn TPE based on the submitted documents.
408. When the designation of a TPE is reinstated, the secretariat makes the name of the TPE and its reinstated sectoral scopes publicly available through the JCM website without delay.

Annex 1: Sectoral Scopes for the JCM

1. Energy industries (renewable - / non-renewable sources)
2. Energy distribution
3. Energy demand
4. Manufacturing industries
5. Chemical industry
6. Construction
7. Transport
8. Mining/Mineral production
9. Metal production
10. Fugitive emissions from fuels (solid, oil and gas)
11. Fugitive emissions from production and consumption of halocarbons and sulphur hexafluoride
12. Solvents use
13. Waste handling and disposal
14. Afforestation and reforestation
15. Agriculture

Annex 2: Application form for designation as a TPE

Name of entity		
Central office	Physical address	
	Postal address (if different from above)	
	Contact details	Telephone: Mobile: Email:
Office in Japan, if applicable	Physical address	
	Postal address (if different from above)	
	Contact details	Telephone: Mobile: Email:
Office in the host country, if applicable	Physical address	
	Postal address (if different from above)	
	Contact details	Telephone: Mobile: Email:
Application condition	Check as appropriate <input type="checkbox"/> Accredited under ISO 14065 by an accreditation body that is a member of the International Accreditation Forum based on ISO 14064-2.	
	Sectoral scope(s) for validation	
	Sectoral scope(s) for verification	
	<input type="checkbox"/> A Designated Operational Entity (DOE) or an operational entity accredited by the Executive Board under the Clean Development Mechanism (CDM).	
	Sectoral scope(s) for validation	
	Sectoral scope(s) for verification	
	<input type="checkbox"/> A Designated Operational Entity (DOE) accredited by the Supervisory Body of the Article 6.4 Mechanism.	
	Sectoral scope(s) for validation	
	Sectoral scope(s) for verification	
	Sectoral scope (s) applied for	Validation (Explanation for selecting the scope(s))
Verification (Explanation for selecting the scope(s))		
Type of application	Check as appropriate <input type="checkbox"/> Initial designation <input type="checkbox"/> Addition of sectoral scopes <input type="checkbox"/> Reinstatement of designation	
	I declare that the information given in this application is correct to the best of my knowledge and belief. I conduct to inform the secretariat immediately of any changes with respect to the application and accept full responsibility for any costs incurred as a result of any changes not reported to the secretariat in line with the procedures for designation. On behalf of the entity, I declare that all the applicable JCM rules and guidelines are understood.	
Name		
Position (state position if other than CEO)		
Date		
Signature		

Joint Crediting Mechanism Guidelines for Validation and Verification

CONTENTS

1. Objectives.....	61
2. Scope and applicability	61
3. Normative references	61
4. Terms and definitions	61
5. General validation and verification procedures.....	61
5.1. Sampling.....	62
6. Validation requirements.....	62
6.1. General requirements.....	62
6.2. Project design document form	63
6.3. Project description	63
6.4. Application of approved methodology(ies).....	63
6.5. Emission sources and calculation of emission reductions	63
6.6. Environmental impact assessment.....	64
6.7. Local stakeholder consultation	64
6.8. Monitoring	64
6.9. Public inputs	65
6.10. Modalities of communications.....	65
6.11. Avoidance of double registration	65
6.12. Ownership.....	66
6.13. Materiality.....	66
6.14. Start of operation.....	66
7. Validation report.....	66
8. Verification requirements	67
8.1. General requirements.....	67
8.2. Verification of compliance.....	68
8.3. Post registration changes.....	69
9. Verification report.....	70

1. Objectives

409. The objectives of the “Joint Crediting Mechanism Guidelines for Validation and Verification” (hereinafter referred to as these Guidelines) are to:
- (a) Enhance consistency and clarity of minimum requirements for all types of Joint Crediting Mechanism (hereinafter referred to as “JCM”) validation and verification activities;
 - (b) Enhance the quality and consistency in the preparation, execution, and the reporting of JCM validation and verification activities.

2. Scope and applicability

410. These Guidelines are applicable to third-party entities (hereinafter referred to as the “TPEs”) that are under a contractual arrangement with project participants to validate or verify any JCM projects based on JCM methodologies previously approved by the Joint Committee.
411. These Guidelines describe standards which are requirements to be met, except guidance indicated with terms “should” and “may” as defined in paragraph 419 below.

3. Normative references

412. The following referenced documents are indispensable for the application of these Guidelines:
- (a) “ISO/IEC 17029:2019 Conformity assessment — General principles and requirements for validation and verification bodies”
 - (b) “ISO 14064-3:2019 Greenhouse gases -- Part 3: Specification with guidance for the verification and validation of greenhouse gas statements” (hereinafter referred to as the “ISO 14064-3”);
 - (c) “Joint Crediting Mechanism Project Cycle Procedure” (hereinafter referred to as the “Project Cycle Procedure”);
 - (d) “Joint Crediting Mechanism Guidelines for Developing Project Design Document and Monitoring Report” (hereinafter referred to as the “PDD and Monitoring Guidelines”).

4. Terms and definitions

413. Engagement is an arrangement between the TPE and its client with the terms to perform services, usually specified in the form of a contract.
414. Validation is the process of independent evaluation of a proposed JCM project by a TPE against these Guidelines.
415. Verification is the periodic independent review and *ex post* determination of monitored GHG emission reductions or removals for a specific monitoring period of a registered JCM project conducted by a TPE.
416. A Corrective Action Request (CAR) is a request raised by the TPE to project participants during validation or verification in cases such as when there has been a mistake, the validation or verification requirements not been met or there is a risk that the emission reductions or removals cannot be monitored or calculated.
417. A Clarification Request (CL) is a request raised by the TPE to project participants during validation or verification when the information provided is insufficient or unclear.
418. A Forward Action Request (FAR) is a request raised by the TPE to project participants during validation to identify issues that require review during the first verification of the project, or during verification if monitoring and reporting require attention and/or adjustment for the next verification.
419. The following terms apply in these Guidelines:
- (a) “Should” is used to indicate that among several possibilities, one course of action is recommended as particularly suitable;
 - (b) “May” is used to indicate what is permitted.
420. Terms in these Guidelines are defined in “JCM Glossary of Terms” available on the JCM website.

5. General validation and verification procedures

421. Validation and/or verification commence(s) when the TPE enters into contract for validation and/or verification with the project participant.
422. Validation and verification of the project may be conducted by the same TPE.
423. Validation and verification may be conducted either simultaneously or separately.
424. The TPE selects a competent team to perform the validation and verification of the project.
425. In carrying out its validation and verification work, the TPE:
- (a) Follows these Guidelines and integrates its provisions into the TPE’s own quality management systems;
 - (b) Applies the most recent decisions by the Joint Committee;
 - (c) Confirms the following aspects of the engagement in line with ISO 14064-3:2019:
 - (i) type and objective: validation / verification;
 - (ii) scope: boundaries, facilities, physical infrastructure, activities, technologies, processes, GHG source and sink, types of GHG, time period, secondary effects, and reference emissions (baselines);
 - (iii) criteria: materiality and level of assurance.
 - (d) Assesses the accuracy, conservativeness, relevance, completeness, consistency, and transparency of the information

- provided by project participants;
- (e) Determines whether information provided by the project participants is reliable and credible;⁵
- (f) Applies consistent validation and verification criteria:
 - (i) To the requirements of the applicable approved methodology;
 - (ii) Among projects with similar characteristics such as a similar application of the approved methodology, use of technology, time period or region;
 - (iii) To expert judgments, over time and among projects.
- (g) Bases its findings and conclusions on objective evidence and conducts all validation and verification activities in line with JCM rules and guidelines;
- (h) Does not omit evidence that is likely to alter the validation and verification opinion;
- (i) Presents information in the validation and verification reports in a factual, neutral and coherent manner, documents all assumptions, provides references to background material, and identifies changes made to documentation;
- (j) Safeguards the confidentiality of all information obtained or created during validation or verification.

5.1. Sampling

426. Where the TPE applies sampling as a part of its validation and verification activities, the TPE samples in line with the “Standard for sampling and surveys for CDM project activities and programme of activities” for large scale CDM projects.

6. Validation requirements

6.1. General requirements

6.1.1. Validation approach

427. In carrying out its validation activities, the TPE:

- (a) Determines whether the proposed JCM project complies with the requirements of the applied methodology(ies), these Guidelines and decisions by the Joint Committee;
- (b) Assesses the claims and assumptions made in the project design document (hereinafter referred to as “PDD”) and modalities of communication statement (hereinafter referred to as “MoC”). The evidence used in this assessment is not limited to that provided by the project participants.

6.1.2. Means of validation

428. The TPE assesses the information provided by the project participants.

429. In assessing information, the TPE applies the means of validation specified throughout these Guidelines, including but not limited to:

- (a) Document review;
- (b) Follow-up actions (e.g. on-site visit and interviews by telephone and/or email) as deemed necessary;
- (c) Reference to available information relating to projects or technologies similar to the proposed JCM project under validation.

430. Where no specific means of validation is specified, the TPE applies appropriate auditing techniques.

Corrective action requests, clarification requests, and forward action requests

431. During the validation of a project, if the TPE identifies issues that require further elaboration, research or expansion in order to determine whether the project meets the validation requirements, the TPE ensures that these issues are accurately identified, formulated, discussed and concluded in the validation report.

432. The TPE raises a CAR if one of the following situations occur:

- (a) The project participants have made mistakes in the PDD and the MoC;
- (b) The applicable validation requirements as defined in these Guidelines have not been met;
- (c) There is a risk that emission reductions or removals cannot be monitored or calculated.

433. The TPE raises a CL if information is insufficient or not clear enough to determine whether the validation requirements have been met.

434. The TPE raises a FAR during validation to identify issues related to project implementation that require review during the first and subsequent verifications of the project. The TPE does not raise a FAR regarding issues which can be concluded before verification.

435. The TPE resolves or “closes out” CARs and CLs only if the project participants modify the project design, rectify the PDD or provide additional explanations or evidence that satisfy the TPE’s concerns. If this is not done, the TPE does not provide a positive validation opinion.

436. The TPE reports on all CARs, CLs and FARs in its validation report. This reporting explains the issues raised, the responses provided by the project participants, the means of validation of such responses and references to any resulting changes in the

⁵ Information is credible if it is authentic and is able to inspire belief or trust, and the willingness of persons to accept the quality of evidence. Information is reliable if the quality of evidence is accurate and credible and able to yield the same results on a repeated basis.

PDD or supporting annexes.

6.2. Project design document form

Validation requirement

437. The TPE determines whether the PDD was completed using the latest version of the PDD forms appropriate to the type of project and drafted in line with the PDD and Monitoring Guidelines.

Reporting requirements

438. The TPE provides a statement regarding the compliance of the PDD with relevant forms and guidance.

6.3. Project description

Validation requirement

439. The TPE determines whether the description of the proposed JCM project in the PDD is accurate and complete and provides an understanding of the proposed JCM project, including malfunctioning of the project equipment, discontinuation of the project, omission of data, and intentional misstatement or noncompliance with laws and regulations which could prevent the achievement of the planned emission reductions or removals.

Means of validation

440. The TPE should conduct an on-site visit as deemed necessary. For proposed JCM projects for which the TPE does not undertake an on-site inspection, the reasons for this are justified. The TPE may apply a sampling approach as deemed appropriate.

Reporting requirements

441. The TPE:

- (a) Describes the process conducted to validate the accuracy and completeness of the project description;
- (b) Provides an opinion on the accuracy and completeness of the project description;
- (c) Provides a justification if it has not conducted an on-site visit.

6.4. Application of approved methodology(ies)

Validation requirement

442. The TPE validates that the project is eligible for applying selected methodology and that the applied version is valid at the time of submission of the proposed JCM project for validation.

Means of validation

443. The TPE determines whether the methodology is correctly quoted and applied by comparing it with the actual text of the applicable version of the methodology.

444. If the PDD of a proposed JCM project is based on a previous version of a methodology whose validity has expired, the TPE requests the project participants to provide a revised PDD in line with the Project Cycle Procedure.

445. The TPE determines whether the project meets each eligibility criterion of the approved methodology or any other approved methodology component if referred to therein. This is done by checking the documentation referred to in the PDD and by reviewing comparable information as deemed necessary to confirm that the project meets the eligibility criteria of the methodology.

Reporting requirements

446. For each eligibility criterion listed in the approved methodology applied, the TPE describes the steps taken to assess the relevant information contained in the PDD against these criteria.

6.5. Emission sources and calculation of emission reductions

Validation requirement

447. The TPE determines whether all relevant GHG emission sources covered in the methodology are addressed for the purpose of calculating project emissions and reference emissions for the proposed JCM project.

448. The TPE determines whether the values for project specific parameters to be fixed *ex ante* listed in the Monitoring Plan Sheet are appropriate, if applicable.

Means of validation

449. The TPE confirms the emission sources and GHGs based on documented evidence and corroborates it by a site visit where required.

450. If the methodology allows project participants to choose whether a source or gas is to be included, the TPE determines whether the project participants have justified that choice. The TPE determines whether the justification provided is reasonable, based on an assessment of supporting documented evidence provided by the project participants and corroborated by observations if required.

451. The TPE ensures that the Monitoring Spreadsheet is not altered, and its required fields are appropriately filled in.
452. If values for project specific parameters are fixed *ex ante*, the TPE determines whether all data sources and assumptions are appropriate and calculations are correct as applicable to the proposed JCM project.

Reporting requirements

453. The TPE describes how the validation of emission sources and GHG types has been performed, by detailing the documentation assessed and by describing its observations.
454. The TPE states whether the selected emission sources and GHG types are justified for the JCM project. Should the TPE identify emission sources that will be affected by the implementation of the proposed JCM project and which are significantly and reasonably attributable to the project and are not addressed by the applied approved methodology, the TPE informs the Joint Committee and the project participants of such findings by electronic means.
455. The TPE describes the steps taken to assess values for project specific parameters to be fixed *ex ante* in the Monitoring Plan Sheet and intermediate processes to derive the values. The TPE provides an opinion as to whether those are considered reasonable in the context of the proposed JCM project.

6.6. Environmental impact assessment

Validation requirement

456. The TPE determines whether the project participants conducted an environmental impact assessment, if required by (*Partner Country*), in line with the (*Partner Country*) procedures.

Means of validation

457. The TPE assesses the above requirements by means of a document review and/or using local official sources and expertise.

Reporting requirements

458. The TPE indicates whether the project participants have conducted an environmental impact assessment in line with procedures as required by (*Partner Country*).

6.7. Local stakeholder consultation

Validation requirement

459. The TPE determines whether the project participants have completed a local stakeholder consultation process and that due steps were taken to engage stakeholders and solicit comments for the proposed project.

Means of validation

460. The TPE determines, by means of document review and interviews with local stakeholders as appropriate, whether:
- (a) Comments have been invited from local stakeholders that are relevant for the proposed project;
 - (b) The summary of the comments received as provided in the PDD is complete;
 - (c) The project participants have taken due account of all comments received and have described this process in the PDD.

Reporting requirements

461. The TPE:
- (a) Describes the steps taken to assess the adequacy of the local stakeholder consultation;
 - (b) Provides an opinion on the adequacy of the local stakeholder consultation.

6.8. Monitoring

Validation requirement

462. The TPE determines whether the description of the monitoring plan (Monitoring Plan Sheet and Monitoring Structure Sheet) is based on the approved methodology and/or PDD and Monitoring Guidelines.
463. The TPE determines whether the monitoring points for measurement are appropriate, as well as whether the types of equipment to be installed are appropriate if necessary. The TPE determines whether the uncertainty has been addressed appropriately.

Means of validation

464. The TPE applies a two-step process to meet the above requirements:
- (a) To assess compliance of the monitoring plan with the approved methodology and/or PDD and Monitoring Guidelines, the TPE:
 - (i) Identifies the list of parameters required by the applied methodology by means of document review;
 - (ii) Confirms that they are described and that the means of monitoring described in the plan complies with the requirements of the methodology.
 - (b) To assess the implementation of the plan the TPE assesses whether:
 - (i) The monitoring structure described in the Monitoring Structure Sheet of the monitoring plan are feasible within the project design;

- (ii) The means of implementation of the monitoring plan, including the data management and quality assurance and quality control procedures, are sufficient for *ex post* reporting and verification.

Reporting requirements

465. The TPE:

- (a) States its opinion on the compliance of the described monitoring plan with the requirements of the methodology and/or PDD and Monitoring Guidelines;
- (b) States its opinion on the project participants' ability to implement the described monitoring plan including feasibility of monitoring structure.

6.9. Public inputs

Validation requirement

466. The TPE ensures that all inputs on the PDD of the proposed JCM project submitted in line with the Project Cycle Procedure are taken into due account by the project participants.

Means of validation

467. The TPE reviews all inputs on the PDD of the proposed JCM project submitted in line with the Project Cycle Procedure.

468. The TPE interviews with the project participants as necessary to determine whether the project participants have taken due account of the public inputs.

Reporting requirement

469. The TPE reports the details of the actions taken to take due account of the inputs received during the public inputs.

6.10. Modalities of communications

Validation requirement

470. The TPE validates the corporate identity of all project participants and a focal point included in the MoC, as well as the personal identities, including specimen signatures and employment status, of their authorized signatories.

471. The TPE validates that the MoC has been correctly completed and duly authorized.

Means of validation

472. The TPE validates the requirements delineated in paragraph 470 above through:

- (a) Directly checking evidence for corporate, personal identity and other relevant documentation;
- (b) Notarized documentation; or
- (c) Written confirmation from the project participant that submits to it the MoC that all corporate and personal details, including specimen signatures, are valid and accurate.

473. When the TPE validates identity by applying paragraph 472(c) above, the TPE ensures that the MoC is received from a project participant with whom the TPE has a contractual relationship.

474. When the TPE validates identity by applying paragraph 472(c) above, the TPE ensures that the official who submits the MoC to the TPE and the official who signed the written confirmation (if a different person) is/are duly authorized to do so on behalf of the respective project participant.

475. If the TPE is unable to validate the requirements by applying paragraph 472 (a), (b) or (c) above then the TPE may perform further validation activities in order to confirm that the corporate and personal details, employment status and specimen signatures included in the MoC are valid and accurate and comply with the requirements of this section.

476. The TPE checks that:

- (a) The latest version of the form for the MoC has been used;
- (b) The information required as per the form for the MoC is correctly completed.

Reporting requirements

477. The TPE describes how it has performed due diligence on the MoC in line with the requirements established in these Guidelines.

478. The TPE describes how the MoC complies with all relevant forms and requirements.

6.11. Avoidance of double registration

Validation requirement

479. The TPE determines whether the proposed JCM project is not registered under other GHG mitigation crediting mechanisms.

Means of validation

480. The TPE receives a written confirmation in the MoC from the project participants that the proposed JCM project is not registered under other GHG mitigation crediting mechanisms.

481. In addition to the above, the TPE conducts, at a minimum, a search on the websites of CDM, JI and the Article 6.4 mechanism to check whether the projects with similar technology and location have been registered. When projects with similar technology

and location are found, the TPE ensures, through document review and/or interviews with the project participants on whether the proposed JCM project differs from projects registered under other GHG mitigation crediting mechanisms.

Reporting requirements

482. The TPE provides an opinion on whether the proposed JCM project is not registered under other GHG mitigation crediting mechanisms.

6.12. Ownership

Validation requirement

483. The TPE assesses whether the project participants have the right to claim emission reductions or removals.

Means of validation

484. The TPE receives contracts from the project participants to clarify that no other entity has the right to claim emission reductions or removals.

485. The TPE conducts interviews with the project participants as necessary to determine whether the project participants have the right to claim emission reductions or removals.

Reporting requirement

486. The TPE provides an opinion on whether the project participants have the right to claim emission reductions or removals.

6.13. Materiality

487. The TPE uses the concept of materiality for validation in line with ISO 14064-3:2019.

488. The threshold of materiality for validation is set at five (5) percent of estimated emission reductions or removals.

6.14. Start of operation

Validation requirement

489. The TPE validates the start of the operating date of the proposed JCM project.

Means of validation

490. The TPE conducts a review of documents and records of operation and performance as appropriate. The TPE should conduct an on-site visit as deemed necessary.

Reporting requirements

491. The TPE provides an opinion on the start of the operating date of the proposed JCM project.

7. Validation report

492. The TPE reports the results of its assessment in a validation report using the latest version of the validation report form which is available on the JCM website.

493. The TPE states in the validation report either of the following final validation opinion:

- (a) A positive validation opinion with a date of submission; or
- (b) A negative validation opinion explaining the reason for its opinion if the TPE determines that the proposed JCM project does not fulfill the applicable JCM requirements or the information provided by the project participants is insufficient.

494. The validation report gives an overview of the validation conclusions and the validation process used by the TPE. All validation findings are identified and justified.

495. In its validation report, the TPE provides the following:

- (a) A summary of the validation process and its conclusions;
- (b) All its applied approaches, findings and conclusions;
- (c) Information on public inputs carried out by the Joint Committee, including dates and how inputs received have been taken into account by the project participants;
- (d) Responses of the project participants to CARs and CLs, and discussions on and revisions to project documentation;
- (e) A list of interviewees and documents reviewed;
- (f) Details of the validation team, technical experts, internal technical reviewers involved, together with their roles in the validation activity and details of who conducted the on-site visit;
- (g) Information on quality control within the team and in the validation process;
- (h) Appointment certificates or curricula vitae of the TPE's validation team members, technical experts and internal technical reviewers for the project.

496. The TPE accredited under ISO 14065 includes the symbol of the accreditation body in the validation report.

497. The TPE provides the project participants with the report along with the supporting documents and informs the Joint Committee of the outcome.

8. Verification requirements

8.1. General requirements

8.1.1. Verification approach

498. In carrying out its verification activities, a TPE determines whether the project complies with the requirements of the applied methodology(ies), these Guidelines, and decisions by the Joint Committee.
499. Main focus of verification activities are given to the assessment of the following aspects:
- The eligibility criteria which are stipulated in the applied methodology of implemented projects are satisfied;
 - The data used in monitoring reports is credible and reliable;
 - Double registration is avoided;
 - There are no post registration changes which prevent the use of the applied methodology.
500. The assessment described in paragraph 499 above involves a review of relevant documentation as well as an on-site visit(s) at least for the first verification.
501. In addition to the documentation concerning monitoring activity the TPE reviews:
- The registered PDD, including any approved changes from the registered PDD and the corresponding validation opinion;
 - The validated PDD in case validation and verification are conducted simultaneously and the corresponding validation opinion;
 - The validation report;
 - Previous verification reports, if any;
 - The applied methodology;
 - The monitoring report to verify that it is as per the corresponding Monitoring Report Sheet to the applied methodology;
 - Any other information and references relevant to the project's emission reductions or removals (e.g. IPCC reports, data on laboratory analysis and national regulations);
 - The written confirmation of the avoidance of double registration.
502. In addition to reviewing the monitoring documentation, the TPE determines whether the project participants have addressed the FARs identified during validation or previous verification(s).

Quality of evidence

503. When verifying the reported emission reductions or removals, the TPE confirms that there is an audit trail that contains the evidence and records that validate or invalidate the stated values in the Monitoring Report Sheet. It includes the source documents that form the basis for calculations and other information underlying the emission reductions or removals.
504. When assessing the audit trail, the TPE:
- Addresses whether there is sufficient evidence available, both in terms of frequency (time period between evidence) and coverage (in covering the full monitoring period);
 - Addresses the source and nature of the evidence (external or internal, oral or documented).
505. The TPE only verifies emission reductions or removals that are based on verifiable evidence.

8.1.2. Means of verification

506. The TPE assesses the information provided by the project participants.
507. In assessing information, the TPE applies the means of verification specified throughout these Guidelines, including but not limited to:
- Document review; and
 - On-site assessment.
508. Where no specific means of verification is specified, the TPE applies appropriate auditing techniques.

Corrective action requests, clarification requests, and forward action requests

509. The TPE identifies, discusses and concludes in the verification report issues related to the monitoring, implementation and operations of the registered/validated project that could impair the capacity of the registered/validated project to achieve emission reductions or removals or influence the monitoring and reporting of emission reductions or removals.
510. The TPE raises a CAR if one of the following situations occur:
- Non-compliance with the eligibility criteria of the applied methodology is found in implementation and operation of the project, or if the evidence provided to prove conformity is insufficient;
 - Modifications, which prevent the use of the applied methodology, to the implementation, operation and monitoring of the registered/validated project has not been sufficiently documented by the project participants;
 - Mistakes have been made in applying assumptions, data or calculations of emission reductions or removals that will impact the quantity of emission reductions or removals; or
 - Issues identified in a FAR during validation or previous verification(s) to be verified have not been resolved by the project participants.
511. The TPE raises a CL if information is insufficient or not clear enough to determine whether the applicable requirements of the applied methodology and the PDD have been met.

512. All CARs and CLs raised by the TPE during verification are resolved prior to submitting a request for issuance of credits.
513. The TPE raises a FAR during verification for actions if the monitoring and reporting require attention and/or adjustment for the next verification period.
514. The TPE reports on all CARs, CLs and FARs in its verification report. This reporting is conducted in a transparent manner that allows the reader to understand the issue raised, the responses provided by the project participants, the means of verification of such responses and references to any resulting changes in the monitoring report or supporting annexes.

8.1.3. Level of assurance

515. The TPE applies the reasonable assurance level for verification in line with ISO 14064-3: 2019.

8.1.4. Materiality

516. The TPE uses the concept of materiality for verification in line with ISO 14064-3: 2019.
517. The threshold of materiality for verification is set at five (5) percent of emission reductions or removals.

8.2. Verification of compliance

8.2.1. Compliance of the project implementation with the eligibility criteria of the applied methodology

Verification requirement

518. The TPE determines the conformity of the actual project and its operation with the eligibility criteria of the applied methodology.

Means of verification

519. The TPE assesses, by means of an on-site visit, that physical features of the project are in place and that the project participants have operated the project as per the eligibility criteria of the applied methodology. If an on-site visit is not conducted after the first verification, the TPE justifies the rationale of the decision.

Reporting requirements

520. For each monitoring period, the TPE reports the compliance with the eligibility criteria of the applied methodology.

8.2.2. Assessment of the project implementation against the registered PDD or any approved revised PDD

Verification requirement

521. The TPE assesses the status of the actual project and its operation with the registered/validated PDD or any approved revised PDD.

Means of verification

522. The TPE assesses, by means of an on-site visit at least for the first verification, that physical features of the project in the registered/validated PDD are in place and that the project participants have operated the project as per the registered/validated PDD or any approved revised PDD.

Reporting requirements

523. For each monitoring period, the TPE reports changes from the registered or validated PDD or any approved revised PDD.

8.2.3. Compliance of calibration frequency and correction of measured values with related requirements

Verification requirement

524. If monitoring of parameters related to the GHG emission reductions or removals of a project has been conducted by measuring equipment (monitoring Option C defined in the PDD and Monitoring Guidelines), the TPE determines whether the measuring equipment has been properly calibrated in line with the monitoring plan and whether measured values are properly corrected, where necessary, to calculate emission reductions or removals in line with the PDD and Monitoring Guidelines.

Means of verification

525. If monitoring of parameters related to the GHG emission reductions or removals of the project has been conducted by measuring equipment (monitoring Option C defined in the PDD and Monitoring Guidelines), the TPE determines whether the measuring equipment has been properly calibrated in line with the monitoring plan.
526. If the measuring equipment is:
- (a) Properly calibrated in line with the monitoring plan, the TPE determines whether the measured values are properly corrected, where necessary, to calculate emission reductions or removals in line with the PDD and Monitoring Guidelines;
 - (b) Not properly calibrated in line with the monitoring plan, the TPE determines whether the result of a delayed calibration is allowed to be used to calculate emission reductions or removals in line with the PDD and Monitoring Guidelines. If the result of a delayed calibration is:
 - (i) Allowed to be used, the TPE determines whether the measured values are properly corrected, where necessary, based on the result of the delayed calibration in line with the PDD and Monitoring Guidelines;

- (ii) Not allowed to be used, the measured values are not used for that monitoring period.
527. Where using the result of a delayed calibration is allowed as described in paragraph 526(b)(i), if the results of the delayed calibration are not available or the calibration has not been conducted at the time of verification, the TPE requests, prior to finalizing verification, the project participants to conduct the required calibration.
528. In cases where the TPE determines that it is not possible for the project participants to conduct the calibration at a frequency specified by either the applied methodology and/or the registered monitoring plan due to reasons beyond the control of project participants, the TPE seeks guidance from the Joint Committee.

Reporting requirements

529. The TPE lists each parameter which has been monitored by measuring equipment and states whether the calibration of the measuring equipment is properly conducted in line with the monitoring plan and whether the measured values are appropriately corrected, if necessary, in line with the PDD and Monitoring Guidelines.

8.2.4. Assessment of data and calculation of GHG emission reductions

Verification requirement

530. The TPE assesses the data and calculations of GHG emission reductions or removals achieved by/resulting from the project by the application of the selected approved methodology. The TPE determines whether the uncertainty has been addressed appropriately.

Means of verification

531. The TPE determines whether:
- (a) The corresponding Monitoring Report Sheet of the applied methodology has been used;
 - (b) A complete set of data for the specified monitoring period is available. If partial data are unavailable, the TPE either gives negative verification opinion for that time period during which the data are unavailable in the monitoring period or seeks guidance from the Joint Committee;
 - (c) Information provided in the monitoring report has been checked with sources such as plant logbooks, inventories, purchase records, laboratory analysis;
 - (d) Any assumptions used in emission calculations have been justified;
 - (e) Appropriate emission factors, default values, and other reference values have been correctly applied.

Reporting requirement

532. The verification report contains:
- (a) A confirmation that appropriate Monitoring Report Sheet of the applied methodology has been used;
 - (b) A confirmation that a set of data for the specified monitoring period was complete, or a list of actions taken by the TPE in line with the guidance from the Joint Committee when partial data are unavailable;
 - (c) A description of how the TPE checked reported data;
 - (d) An opinion as to whether assumptions, emission factors, default values, and other reference values that were applied in the calculations have been justified.

8.2.5. Assessment of avoidance of double registration

Verification requirement

533. The TPE determines whether the project is not registered under other GHG mitigation crediting mechanisms.

Means of verification

534. The TPE receives a written confirmation from the project participants that the project is not registered under other GHG mitigation crediting mechanisms.
535. In addition to paragraph 534 above, the TPE conducts, at a minimum, a search on the website of the CDM, JI and the Article 6.4 mechanism to check whether the projects with similar technology and location in (*Partner Country*) have been registered. When projects with similar technology and location are found, the TPE ensures, through document review and/or interviews with the project participants on whether the project differs from projects registered under other GHG mitigation crediting mechanisms.

Reporting requirement

536. The TPE provides an opinion on whether the project is not registered under other GHG mitigation crediting mechanisms.

8.3. Post registration changes

Verification requirement

537. The TPE determines whether there are post registration changes from the registered PDD and/or methodology which prevent the use of the applied methodology.

Means of verification

538. If the TPE identifies that the project has been changed from the registered PDD and/or methodology and that change would prevent the use of the applied methodology, the TPE raises a CAR and requests the project participants to seek prior approval from the Joint Committee with respect to the acceptability of the changes.
539. The TPE continues verification following guidance from the Joint Committee.

Reporting requirements

540. Where the change which prevents the use of the applied methodology is identified during verification and the Joint Committee approves the change, the TPE indicates in the verification report the types of change, and how the CAR raised is addressed.
541. Where the change which does not prevent the use of the applied methodology is identified during verification, the TPE describes the types of change in the verification report.

9. Verification report

542. The TPE reports the results of its assessment in a verification report using the latest version of the verification report form which is available on the JCM website.
543. The verification report gives an overview of the verification conclusions and the verification process used by the TPE. All verification findings are identified and justified.
544. The TPE reports the following:
- (a) A summary of the verification process and the scope of verification;
 - (b) A summary of the verification results and decision on the level of assurance;
 - (c) Details of the verification team, technical experts, and internal reviewers involved, together with their roles in the verification activity and details of who conducted the on-site visit;
 - (d) Findings of the desk review and site visit;
 - (e) All of the TPE's findings and conclusions as to whether:
 - (i) The project has been implemented and operated in line with the eligibility criteria of the applied methodology;
 - (ii) Omissions or misstatements of reported values are considered as immaterial;
 - (iii) The measuring equipment has been calibrated in line with the monitoring plan and the measured values are corrected appropriately in line with the PDD and Monitoring Guidelines, for parameters monitored under Option C;
 - (iv) The data and calculation of GHG emission reductions or removals have been assessed to correctly support the emission reductions or removals being claimed;
 - (v) The project is not registered under other GHG mitigation crediting mechanisms.
 - (f) A list of each parameter specified by the monitoring plan and a statement on how the values in the monitoring report have been verified;
 - (g) A statement that identifies any changes to the registered PDD, and their date of approval by the Joint Committee;
 - (h) An assessment and close-out of any CARs, CLs or FARs issued to the project participants;
 - (i) An assessment of remaining issues from the previous verification period, if appropriate;
 - (j) A conclusion on the verified amount of emission reductions or removals achieved.
545. The TPE accredited under ISO 14065 includes the symbol of the accreditation body in the verification report.
546. The TPE describes all documentation supporting verification and makes such documentation available to the Joint Committee upon request.

Common Specifications of the JCM Registry

The Joint Committee of the JCM between the Government of Japan and the Government of (*Partner Country*), hereby establishes the common specifications of the JCM registry as follows:

A. Definitions

547. "Issuance" is an operational procedure for a JCM registry manager to record an increase of a specified amount of JCM credits in the holding accounts of project participants and/or the respective governments in line with the corresponding decision by the Joint Committee.
548. "Transfer" is an operational procedure initiated by each government or an account holding entity to move a certain amount of JCM credits from its holding account into another account established in the respective JCM registry.
549. "Acquisition" is an operational procedure for each government or an account holding entity to receive a certain amount of JCM credits in its own holding account established in the respective JCM registry.
550. "Cancellation" is an operational procedure to transfer a certain amount of JCM credits to a cancellation account so that the JCM credits are not further transferred.
551. "Retirement" is an operational procedure to transfer a certain amount of JCM credits to a retirement account so that the JCM credits are used as a part of the internationally pledged greenhouse gases mitigation efforts by the respective countries and not further transferred.

B. Registries

552. Each government establishes and maintains a JCM registry to ensure the accurate accounting of the issuance, holding, transfer, acquisition, cancellation and retirement of JCM credits.
553. Each government designates an organization as its JCM registry manager to maintain its registry. Both governments may voluntarily maintain their respective registries in a consolidated system, provided that each JCM registry remains distinct.
554. A JCM registry is in the form of a database which contains, inter alia, common data elements relevant to the issuance, holding, transfer, acquisition, cancellation and retirement of JCM credits for the purpose of ensuring the accurate, transparent and efficient management of data.
555. Each JCM credit is held in only one account in one JCM registry at a given time.
556. Each JCM registry has the following accounts:
- (a) One holding account for the government;
 - (b) One holding account for each entity authorized by each side;
 - (c) At least one cancellation account for the purpose of cancelling JCM credits; and
 - (d) One retirement account for the purpose of retiring JCM credits.
557. Each account within a JCM registry has a unique account number comprising the following elements:
- (a) Scheme identifier: "JCM" is stated at the beginning of the account number;
 - (b) Country identifier: the country in whose JCM registry the account is maintained, identified by means of the two-letter country code defined by the International Organization for Standardization (ISO 3166); and
 - (c) A unique number: a number unique to that account for the country in whose JCM registry the account is maintained.

C. Issuance of JCM credits

558. Upon being notified by the Joint Committee to issue JCM credits for a JCM project activity, the JCM registry manager issues a specified amount of JCM credits into holding accounts of project participants and/or the respective governments in line with the corresponding decision by the Joint Committee.
559. Each JCM credit has a unique serial number comprising the following elements:
- (a) Identifier of the JCM: "JCM" is used;
 - (b) Identifier of the host country: the host country where the JCM project is registered, identified by means of the two-letter country code defined by the International Organization for Standardization (ISO 3166);
 - (c) Identifier of the country of issuance: the country where the JCM credits are issued, identified by means of the two-letter country code defined by the International Organization for Standardization (ISO 3166);
 - (d) Identification of year of emission reductions or removals: the year in which emission reductions are achieved, identified by a four-digit number; and
 - (e) Unit: a number unique to the JCM credit for the country of issuance.

D. Transfer, acquisition, cancellation and retirement

560. Account holding entities may transfer and acquire JCM credits between their holding accounts established in their JCM registry.
561. Each government may cancel JCM credits by transferring credits to cancellation accounts in its JCM registry. An account holding entity may also transfer JCM credits into cancellation accounts.

562. Each government may retire JCM credits to be used for achieving its emission reduction target by transferring credits to the retirement account in its JCM registry. An account holding entity may also transfer JCM credits into the retirement account.
563. JCM credits transferred to the cancellation accounts or the retirement account are not further transferred.

E. Transaction record

564. Each government establishes and maintains a transaction record to verify the validity of transactions, including issuance, transfer and acquisition between accounts in its JCM registry and cancellation and retirement of JCM credits.

F. Publicly accessible information

565. Each government makes non-confidential information publicly available and provides a publicly accessible user interface through the Internet that allows interested persons to query and view it.
566. The information referred to in paragraph 565 above includes up-to-date information of the account holding entity's name in the JCM registry.
567. The information referred to in paragraph 565 above includes the following information relevant to the JCM registry for each calendar year (defined in line with Greenwich Mean Time):
- (a) The total amount of JCM credits per type of account (holding, cancellation or retirement) in the JCM registry at the beginning of the year;
 - (b) The total amount of JCM credits issued on the basis of notification for issuance of JCM credits by the Joint Committee;
 - (c) The total amount of JCM credits cancelled; and
 - (d) The total amount of JCM credits retired.