

JCM Project Design Document Form

A. Project description

A.1. Title of the JCM project

Energy saving through introduction of Regenerative Burners for aluminum holding furnaces of the automotive components manufacture in the Republic of Indonesia

A.2. General description of project and applied technologies and/or measures

The proposed JCM Project aims to reduce consumption of natural gas and consequently emissions of greenhouse gas (GHG) by replacing conventional burners with regenerative burners for aluminum holding furnaces in the automotive components manufacturing factory. Regenerative burners absorb exhaust gas heat to reservoir and preheat combustion air using the absorbed heat in reservoir to improve energy efficiency.

The project is expected to reduce 23 t-CO₂ of GHG emissions annually through replacement of the eleven conventional burners with regenerative burners at the factory of PT. Yamaha Motor Parts Manufacturing Indonesia (YPMI) in the Karawang International Industrial City (KIIC), Karawang, West Java Province, Indonesia.

In line with the JCM approved methodology ID_AM009, reference emissions are calculated based on the consumption of natural gas in the project furnace and energy efficiency of the reference and project burners, while project emissions are calculated based on the consumption of natural gas and electricity in the project furnace.

A.3. Location of project, including coordinates

Country	The Republic of Indonesia
Region/State/Province etc.:	West Java Province
City/Town/Community etc:	Karawang
Latitude, longitude	S 6° 21' 45" and E 107° 16' 15"

A.4. Name of project participants

The Republic of Indonesia	PT. Yamaha Motor Parts Manufacturing Indonesia (YPMI)
Japan	Toyotsu Machinery Corporation

A.5. Duration

Starting date of project operation	12/01/2015
Expected operational lifetime of project	9 years

A.6. Contribution from developed countries

The proposed JCM Project was partially supported by the Ministry of Environment, Japan through the financing programme for JCM model projects, which provided financial support up to 50% of initial investment for the projects in order to acquire JCM credits.

As for technology transfer, the proposed JCM Project creates opportunities for OJT training of YPMI's Indonesian technicians on operation and maintenance of regenerative burners, which require special skills unique to those burners, and consequently reduces technical and operational impediments to introductions of energy-efficient regenerative burners in Indonesia where energy demands have recently been surging but regenerative burners have been rarely introduced.

The special skills required for operation and maintenance of regenerative burners are, for example:

1. to install the right quantity and density of the heat absorber that is unique to regenerative burners;
2. to operate the burner keeping appropriate air ratio; and
3. to maintain the heat absorber's cleanness and damage within the acceptable range.

B. Application of an approved methodology(ies)

B.1. Selection of methodology(ies)

Selected approved methodology No.	ID_AM009
Version number	1.0

B.2. Explanation of how the project meets eligibility criteria of the approved methodology

Eligibility criteria	Descriptions specified in the methodology	Project information
Criterion 1	The project replaces conventional burners with regenerative burners for aluminum holding furnaces.	The proposed JCM Project replaces the eleven conventional burners with regenerative burners for aluminum holding furnaces in the factory of YPMI.
Criterion 2	Holding temperature of aluminum melt, which is determined in the furnace user's specification, is within the range from 600 to 800 degrees Celsius.	YPMI's specification determines that holding temperature of aluminum melt is within the range from 600 to 800 degrees Celsius.
Criterion 3	The regenerative burners have a structure which leads all exhaust gas to flow through the heat reservoir before discharging it into the atmosphere.	All the regenerative burners introduced in this project have a structure which leads all exhaust gas to flow through the heat reservoir before discharging it into the atmosphere.
Criterion 4	Periodical check is planned at least once a year.	Periodical checks of the aluminum holding furnaces are planned to be conducted once a year in YPMI's specification

C. Calculation of emission reductions

C.1. All emission sources and their associated greenhouse gases relevant to the JCM project

Reference emissions	
Emission sources	GHG type
Combustion of natural gas in the reference furnace	CO ₂
Project emissions	
Emission sources	GHG type
Combustion of natural gas in the project furnace	CO ₂
Power consumption by the project furnace	CO ₂

C.2. Figure of all emission sources and monitoring points relevant to the JCM project

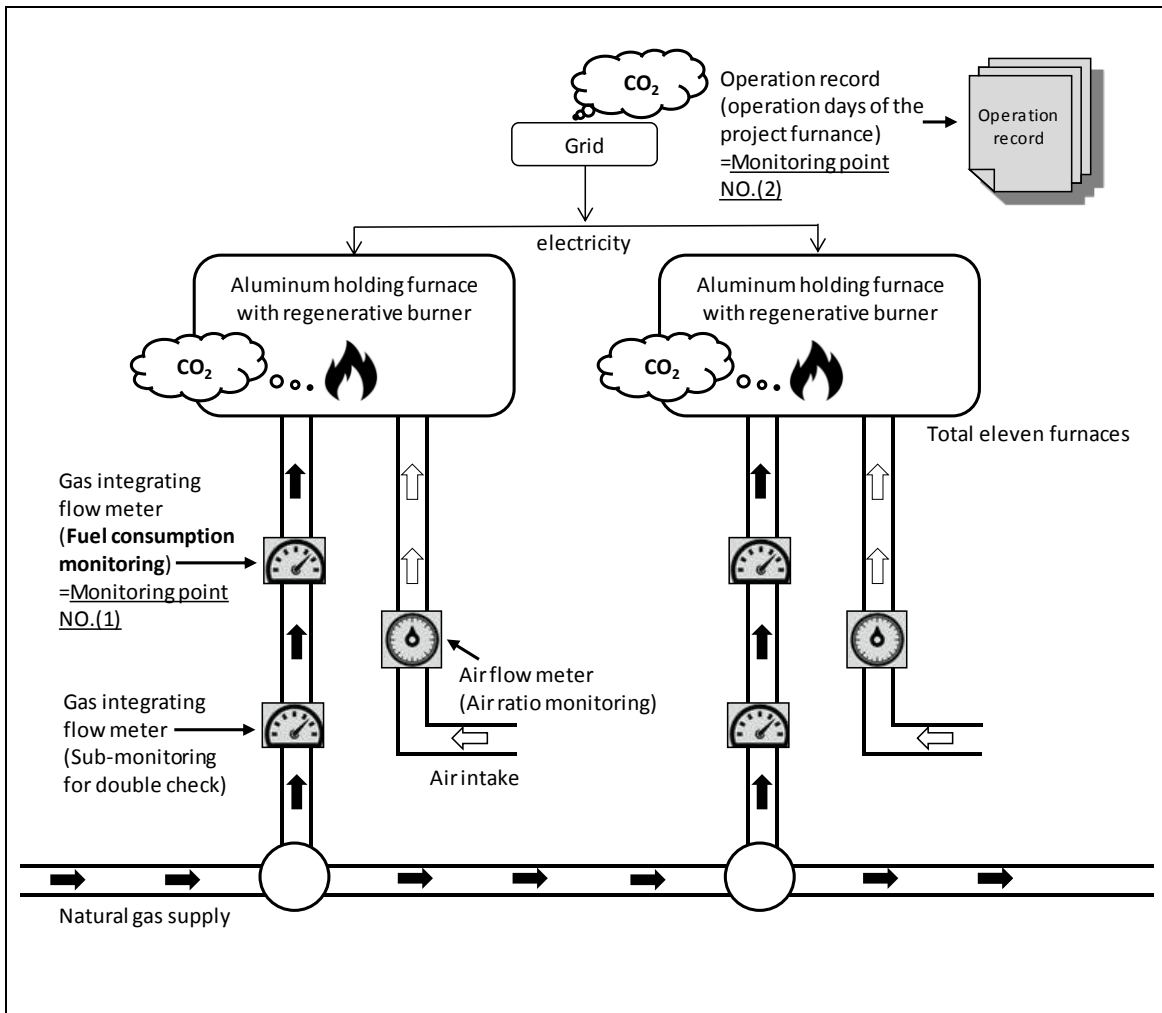

C.3. Estimated emissions reductions in each year

Year	Estimated Reference emissions (tCO _{2e})	Estimated Project Emissions (tCO _{2e})	Estimated Emission Reductions (tCO _{2e})
2013	0	0	0
2014	0	0	0
2015	0	0	0
2016	688.9	665.4	23
2017	688.9	665.4	23
2018	688.9	665.4	23
2019	688.9	665.4	23
2020	688.9	665.4	23
Total (tCO _{2e})	3,444.5	3,327.0	115

D. Environmental impact assessment

Legal requirement of environmental impact assessment for the proposed project	No
---	----

E. Local stakeholder consultation

E.1. Solicitation of comments from local stakeholders

In order to cover a diverse group of stakeholders, in the period from 27 August – 28 August 2015, a series of meetings were conducted with government of West Java Province, Karawang Regency Government and Karawang Chamber of Commerce, and Karawang International Industrial City (KIIC). The schedule of the meetings is provided in the table below.

No	DATE	TIME	ORGANIZATION
1	2015/8/27	08:15-09:15	Government of West Java Province, Industry and Trade Department
2		09:30-10:30	Regional Environmental Management Board of West Java Province, Legal Affairs and Partnership Division
3		11:00-12:00	Regional Development Planning Board of West Java Province, Economic Division and Physical Division (Energy Related)
4		14:00-15:45	Government of West Java Province, International Cooperation Division, Regional Autonomy and Cooperation Bureau
5			Government of West Java Province, Economic Administration Bureau
6		19:00-20:00	Karawang Chamber of Commerce
7	2015/8/28	08:15-11:00	Karawang Regency Government, Economic Bureau/ Board of Investment and Integrated Services
8			Karawang Regency Government, Department of Industry, Trade, Mining, and Energy
9			Regional Environmental Agency of Karawang Regency
10		14:00-15:00	Karawang International Industrial City (KIIC) secretariat

At each meeting, a brief introduction of the project was made and opinions of the stakeholders were solicited. A summary of the comments received is provided in Section E.2. below.

E.2. Summary of comments received and their consideration

Stakeholders	Comments received	Consideration of comments received
Government of West Java Province, Industry and Trade Department	This technology is great because that can contribute energy and climate change issues. Please consider to apply it to other sector.	No action is needed. (Diffusion of this technology is needed)
Regional Environmental Management Board of West Java Province, Legal Affairs and Partnership Division	I understand that regenerative burner is advanced technology. I'd like to support the project.	No action is needed.
Regional Development Planning Board of West Java Province, Economic Division and Physical Division (Energy Related)	Energy saving and environment issues are important for Indonesia government. We would like to help the project if you need.	No action is needed.
Government of West Java Province, International Cooperation Division, Regional Autonomy and Cooperation Bureau	The regenerative burner is energy saving and environment-friendly technology. It can contribute to the government policy.	No action is needed.
Government of West Java Province, Economic Administration Bureau		
Karawang Chamber of Commerce	We will help to diffuse the technology.	No action is needed.
Karawang Regency Government, Economic Bureau/ Board of Investment and Integrated Services	Please consider to diffuse this technology.	No action is needed. (Diffusion of this technology is needed)
Karawang Regency Government, Department of Industry, Trade, Mining, and Energy		
Regional Environmental Agency of Karawang Regency		
Karawang International Industrial City (KIIC) secretariat	We understand the technology and JCM.	No action is needed.

F. References

-

Reference lists to support descriptions in the PDD, if any.

Annex

-

Revision history of PDD

Version	Date	Contents revised
01.0	25/02/2016	First Edition